

# Vlinx “Mini” Serial Server ESP211-232

## User Manual



2009.07.02



## **International Headquarters**

B&B Electronics Mfg. Co. Inc.

707 Dayton Road • Ottawa, IL 61350 USA

**Phone** (815) 433-5100 • **General Fax** (815) 433-5105

Website: [www.bb-elec.com](http://www.bb-elec.com)

**Technical Support** e-mail: [support@bb.elec.com](mailto:support@bb.elec.com) -- **Fax** (815) 433-5100

**Sales** e-mail: [orders@bb-elec.com](mailto:orders@bb-elec.com) -- **Fax** (815) 433-5109

## **European Headquarters**

B&B Electronics Ltd.

Westlink Commercial Park • Oranmore, Co. • Galway, Ireland

**Phone** +353 91-792444 -- **Fax** +353 91-792445

Website: [www.bb-europe.com](http://www.bb-europe.com)

**Sales** e-mail: [sales@bb-europe.com](mailto:sales@bb-europe.com)

**Technical Support** e-mail: [support@bb-europe.com](mailto:support@bb-europe.com)

## **Copyright**

This document contains proprietary information that is protected by copyright. All rights reserved. No part of this document may be photocopied, reproduced, or translated into another language without express prior written consent of the originator. The software described in this manual is furnished under a license agreement and may be used only in accordance with the terms of that agreement.

## **Disclaimer**

Information in this document is subject to change without notice and does not represent a commitment on the part of the originator.

We provide this document “as is,” without warranty of any kind, either expressed or implied, including, but not limited to, its particular purpose. We reserve the right to make improvements and/or changes to this manual, or to the products and/or the programs described in this manual, at any time.

Information provided in this manual is intended to be accurate and reliable. However, we assume no responsibility for its use, or for any infringements on the rights of third parties that may result from its use.

This product might include unintentional technical or typographical errors. Changes are periodically made to the information herein to correct such errors, and these changes are incorporated into new editions of the publication.

## Contents

<b>1. Introduction .....</b>	<b>1</b>
1.1 Main Features .....	1
1.2 Communication Modes.....	1
1.2.1 Straight IP Mode .....	2
1.2.2 Virtual COM Mode .....	2
1.2.3 Paired Mode .....	2
1.2.4 TCP Probe .....	3
1.3 Package Checklist.....	3
<b>2. Hardware and Connections.....</b>	<b>4</b>
2.1 Hardware Links .....	4
2.2 Connectors, Indicators, and Reset Switch .....	4
2.2.1 Indicator Lights .....	4
2.2.2 Power Connector.....	4
2.2.3 Reset Button.....	4
2.2.4 Ethernet Connector .....	4
2.2.5 Serial Port.....	4
2.3 Top/Bottom Views .....	5
2.4 Panel Layouts.....	5
<b>3. Installing the Vlinux Manager Software .....</b>	<b>6</b>
3.1 Software Installation.....	6
3.1.1 Automatic Installation.....	6
3.1.2 Manual Installation .....	6
3.1.3 Updating an Existing Installation.....	6
3.1.4 Opening the Vlinux Manager.....	6
<b>4. Using the Vlinux Manager.....</b>	<b>8</b>
4.1 Hardware Setup .....	8
4.2 Software Setup.....	8
4.3 Software Overview .....	9
4.3.1 Menus.....	9
4.3.2 Icons.....	10
4.3.3 Serial Server List / Virtual COM List .....	11
4.3.4 Status Bar .....	12
4.4 Search for Servers.....	12
4.5 Setting Configurations.....	13

<b>5. Configuring the Vlinux Serial Server</b> .....	<b>15</b>
5.1 Description of Configuration - System.....	15
5.1.1 Model Name.....	15
5.1.2 Server Name.....	15
5.1.3 Serial Number .....	15
5.1.4 Password .....	15
5.1.5 FW Version.....	15
5.1.6 MAC Address.....	16
5.1.7 DHCP.....	16
5.1.8 IP Address .....	16
5.1.9 Netmask .....	17
5.1.10 Gateway .....	17
5.1.11 Link Status .....	17
5.1.12 Default Mode .....	17
5.2 Description of Configuration – Serial Port.....	17
5.2.1 Baud Rate.....	17
5.2.2 Data/Stop bits.....	17
5.2.3 Parity .....	18
5.2.4 Flow Control .....	18
5.2.5 TCP/UDP Protocol.....	18
5.2.6 TCP/UDP Port.....	18
5.2.7 Delimiter Hex 1 and Delimiter Hex 2.....	19
5.2.8 Force Transmit .....	19
5.2.9 Inter-character Gap .....	19
5.2.10 Connection Status .....	19
5.2.11 Serial Type .....	19
5.2.11.1 RS-232 .....	19
5.2.11.2 Console Mode.....	20
5.2.11.3 Upgrade Mode .....	20
5.2.12 Serial Timeout.....	21
5.2.13 TCP Alive Timeout .....	21
5.2.14 TCP Mode .....	21
5.2.15 Max Connection.....	22
5.2.16 Connection At .....	22
5.2.17 Remote IP Address.....	22
5.2.18 Apply.....	22
5.2.18.1 Saving Configuration Data in Vlinux Manager.....	22

5.2.18.2	Saving Configuration Data in Console Mode or Telnet .....	23
5.2.18.3	Saving Configuration Data in Web Server Interface .....	24
<b>6.</b>	<b>Installing Virtual COM Ports .....</b>	<b>25</b>
6.1	Installing Virtual COM Port .....	25
6.2	Matching the Serial Server and Virtual COM Port Settings .....	25
<b>7.</b>	<b>Removing Virtual COM Ports .....</b>	<b>28</b>
7.1	Removing the Virtual COM port using Vlinux Manager .....	28
7.2	Removing the Virtual COM Port using Device Manager.....	28
<b>8.</b>	<b>Upgrading the Vlinux Serial Server Firmware .....</b>	<b>30</b>
8.1.1	Change to Upgrade Mode .....	30
8.1.2	Upgrading the Firmware .....	30
<b>9.</b>	<b>Using Console Mode .....</b>	<b>32</b>
9.1	Entering Console Mode .....	32
9.2	Console Mode Setup.....	32
9.2.1	Navigating the Configuration Menus.....	33
<b>10.</b>	<b>Using the Web Server .....</b>	<b>34</b>
10.1	Setting Server Configurations.....	34
<b>11.</b>	<b>Using Telnet .....</b>	<b>36</b>
11.1	Telnet Login.....	36
11.2	Navigating the Configuration Menu .....	36
<b>12.</b>	<b>Operation Modes.....</b>	<b>37</b>
12.1	Straight IP Mode .....	37
12.2	VCOM Mode .....	39
12.3	Paired Mode.....	41
12.4	UDP Mode .....	42
<b>13.</b>	<b>Technical Data .....</b>	<b>44</b>
13.1	Feature List .....	44
13.2	Default Settings .....	45
<b>Appendix A: Well-Known TCP/UDP Port Numbers .....</b>		<b>46</b>
<b>Appendix B: Serial Port Pin-outs .....</b>		<b>47</b>
DB-9	Pin-outs in RS-232 Mode.....	47
<b>Appendix C: Ethernet Cable Pin-outs .....</b>		<b>48</b>
<b>Appendix D: Regulation Information .....</b>		<b>49</b>

# 1. Introduction

Your **Vlinx Serial Server** provides Ethernet to serial connectivity for industrial serial devices. Your control can extend from virtually anywhere, using TCP/IP or UDP/IP Ethernet connections. The Vlinx Serial Server has an asynchronous RS232 serial port connection on one side, and a 10/100 Mbps Ethernet connection on the other side. It connects devices, such as CNC (computer numerically controlled) devices, weighing scales and scanners. Applications include industrial/factory automation, automatic warehouse control, and hospital/laboratory automation.

The Vlinx Serial Server Windows driver provides Virtual COM port to control the Serial Server. Virtual COM port provides access to any of the ports on the Serial Server, as if they were a real serial port on the computer.

The Vlinx Serial Server can function as a server or client for both TCP and UDP connections. The application scenarios include Straight IP mode, VCOM/TCP mode, Paired or Serial Tunneling mode, UDP overall mode and TCP Server mode. In Straight IP and Virtual COM modes, the Serial Server works only as a server. When in Paired mode one Serial Server must be set as a client and the other as a server, for both TCP and UDP connections.

## 1.1 Main Features

- **10/100 Mbps Ethernet** with Auto-detection
- **TCP or UDP / Client or Server operation**
- **OS Support** - Windows 2000/2003/XP/Vista
- **Firmware Upgrade** for future revisions/upgrades
- **Configuration** of Serial Server settings can be accomplished using any of the following methods:
  - ✓ **Web Server** using any web browser
  - ✓ **Vlinx Manager** via LAN
  - ✓ **Telnet** console via the network
  - ✓ **Serial Console** via the serial port
  - ✓ **Virtual COM Driver Software for Windows** – installs VCOM ports, viewable in the Windows Device Manager under Ports (COM & LPT). The driver installs a virtual COM on Windows, which maps the VCOM port to the IP address and TCP/UDP port of the Serial Server. This enables Windows applications to access remote serial devices over an IP-based Ethernet LAN. The LAN is transparent to the serial device and to software running on the PC.
- **TCP Probe** - selectable protocol ensures reliable communications in Virtual COM mode or Paired mode. This feature restores the connections if communications are temporarily lost at either end due to loss of power or the Ethernet connection.

## 1.2 Communication Modes

The Vlinx Serial Server enables communication with serial devices over a LAN or WAN. Serial devices no longer are limited to a physical connection to the PC COM port. They can be installed anywhere reachable by the LAN/WAN using TCP/IP or UDP/IP communications. This allows traditional Windows PC software access to serial devices anywhere on the LAN/WAN network.

### 1.2.1 Straight IP Mode

Straight IP mode allows applications using TCP/IP or UDP/IP socket programs to communicate with the Serial Server. In this type of application the Serial Server is configured as a TCP or UDP server. The socket program on the PC establishes a connection with the Serial Server. Data is sent directly to and from the serial port on the server. When using UDP the server can be configured to broadcast to and receive data from multiple IP addresses.

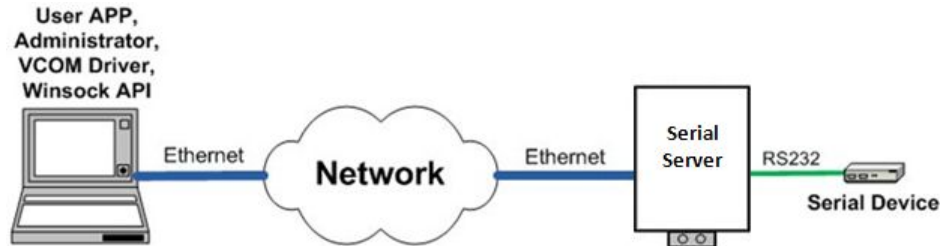

Figure 1 Straight IP Mode / Virtual COM Mode

### 1.2.2 Virtual COM Mode

Virtual COM mode allows the user to provide a virtual COM port on the computer. Windows programs using standard Windows API calls are able to interface to virtual COM ports. When a program on the PC opens the new COM port, it communicates with the remote serial device connected to one of the ports on the Serial Server.

After connection, the LAN is transparent to the program and serial device. Applications are able to work just as if the serial device is connected directly to a physical COM port on the computer. The virtual COM software converts the application's data into IP packets, sends it across the network to the Serial Server, which converts the IP packet back to serial data and sends the data out the RS232 serial port located on the Serial Server.

To use this mode, the Serial Server must be set to either TCP/server or UDP/server with a designated communication port number. The virtual COM driver is the TCP or UDP client.

### 1.2.3 Paired Mode

Paired Mode is also called **Serial Tunneling mode**. In this mode any two serial devices that can communicate with a serial link will be able to communicate using two Serial Servers and the LAN.

The Serial Servers are connected to a network, one configured as a TCP/UDP client and the other as a TCP/UDP server. In the setup the **Remote IP address** field of the server must contain the address of the client. This will allow the client's IP address to bypass the IP address-filtering feature of the server. Conversely, the **Remote IP address** of the client must contain the server's IP address. Both communication port numbers must be the same.

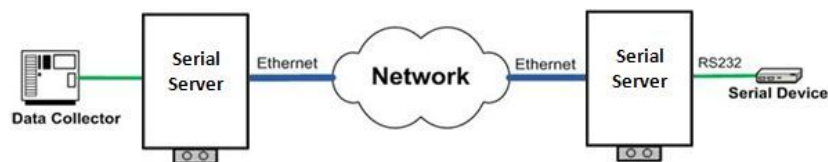

Figure 2 Paired Mode

## 1.2.4 TCP Probe

The TCP Probe protocol provides reliable communication in Virtual COM mode and Paired mode. This restores connections if communications are temporarily lost from loss of power or Ethernet connection. Without this, lost connections would require human intervention. The Probe feature tries to reconnect the TCP data connection every five seconds until communications are re-established. The Probe feature does not apply for UDP applications.

## 1.3 Package Checklist

The Vlinux Serial Server is shipped with the following items included:

- ✓ The Serial Server unit
- ✓ Quick Start Guide
- ✓ CD-ROM Disk with Documentation and Software)

The following items may be necessary to complete your installation, and are not included:

- ✓ Power Adapter
- ✓ Ethernet cable, standard pinout
- ✓ Serial cable w/ DB9 connector, standard pinout
- ✓ Serial cable w/ DB9 connector, null modem pinout
- ✓ DIN rail kit
- ✓ Mounting screws
- ✓ Power surge protection
- ✓ Serial optical isolation

## 2. Hardware and Connections

### 2.1 Hardware Links

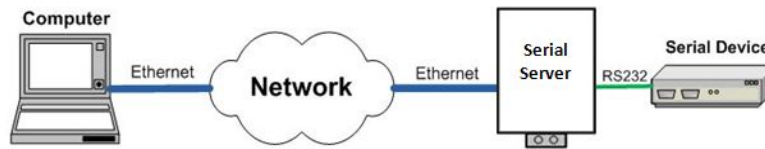

**Figure 3 Typical Hardware Setup**

**Connection 1:** Connect the Serial Server to the network using an Ethernet cable.

**Connection 2:** Connect the Serial Server to the RS-232 port on the serial device.

**Note:** If the serial device is configured as a DCE use a straight-through serial cable. If the serial device is configured as a DTE use a crossover (null modem) cable.

**Connection 3:** Connect power to the Serial Server.

## 2.2 Connectors, Indicators, and Reset Switch

### 2.2.1 Indicator Lights

LED	Status	Indication
Ready (RDY)	Green	Blinking = System ready
LEDs on RJ45 connector	Orange	10BaseT Ethernet connection established
	Green	100BaseT Ethernet connection established
	<i>Blinking</i>	<i>Data link is active</i>
	<i>Steady</i>	<i>Link is connected</i>

### 2.2.2 Power Connector

Connect the included power supply into the power jack and then plug the supply in. When power is applied the Green **Ready** light will blink. The tip of the power plug is positive; the sleeve is negative.

### 2.2.3 Reset Button

This switch resets the unit, similar to the effect of removing/applying power. The Reset switch is recessed to avoid accidental operation. To reset the unit, insert a small plastic tool, press lightly. The Link and Ready lights will go out and then come back on. When the ready light starts blinking on and off in a two second cycle, the system is ready again.

### 2.2.4 Ethernet Connector

The Serial Server has a standard RJ-45 receptacle mounted in the top edge of the chassis. The Serial Server can be connected to an Ethernet hub, switch, or wall plate using a standard straight-through RJ-45 (male) Ethernet cable. To connect directly to an RJ45 Ethernet port on a PC or laptop a crossover Ethernet cable must be used.

### 2.2.5 Serial Port

The serial port will only operate in RS-232 mode.

## 2.3 Top/Bottom Views



Figure 4 Top/Bottom Views

## 2.4 Panel Layouts



Figure 5 Panel Layouts

## 3. Installing the Vlinx Manager Software

The Windows-based **Vlinx Manager** and **Virtual COM Port** software makes configuration fast and easy.

### 3.1 Software Installation

The **Vlinx Manager** software includes:

- ✓ **Vlinx Manager**
- ✓ **Software to Install / Remove Virtual COM Ports\**
- ✓ **Firmware Update Manager** (See Section 8)

#### 3.1.1 Automatic Installation

**Step 1:** Inserting the CD in the CD-ROM to automatically launch the Install Shield Wizard.

#### 3.1.2 Manual Installation

**Step 2:** To manually start the software installation, from the Windows Desktop, click **Start** button and click **Run** item. At the Run command line type E:\Vinx\_Install\setup.exe and click OK (E: is the drive letter for the CD ROM.), or open the File manager and double click E:\Vlinx\_Install\setup.exe.

#### **OR**

Find the file **setup.exe** in the listed files and double click it. Each step has on-screen directions. When Choose Destination Location appears, click **Next**. Installation progress will be shown until complete.

**Step 3:** Click **Finish** when the **Install Shield Wizard Complete** dialogue appears, and the dialogue box will close.

#### 3.1.3 Updating an Existing Installation

If an older version of the **Vlinx Manager** software is already installed, the **Remove the program** window will appear when the installation process is initiated.

Once the software has been removed, **Install** the new software.

#### 3.1.4 Opening the Vlinx Manager

**Step 1:** If the **Serial Server** is not already connected to the network or to the Ethernet port on the computer, connect it. Apply power. The **Link** LEDs on the Ethernet connector should indicate which type of Ethernet connection has been made and the **Ready** LED will flash indicating configuration can begin.

**Step 2:** Start the **Vlinx Manager** software. In Windows Desktop, click:

**Start > Programs > B&B Electronics > Vlinx > Vlinx Servers > Vlinx Manager**

As soon as the **Vlinx Manager** opens it will initiate **Searching Server** and after a few seconds the **IP Serial Server List** will display all **Vlinx Serial Servers (wired or wireless)** on the network.

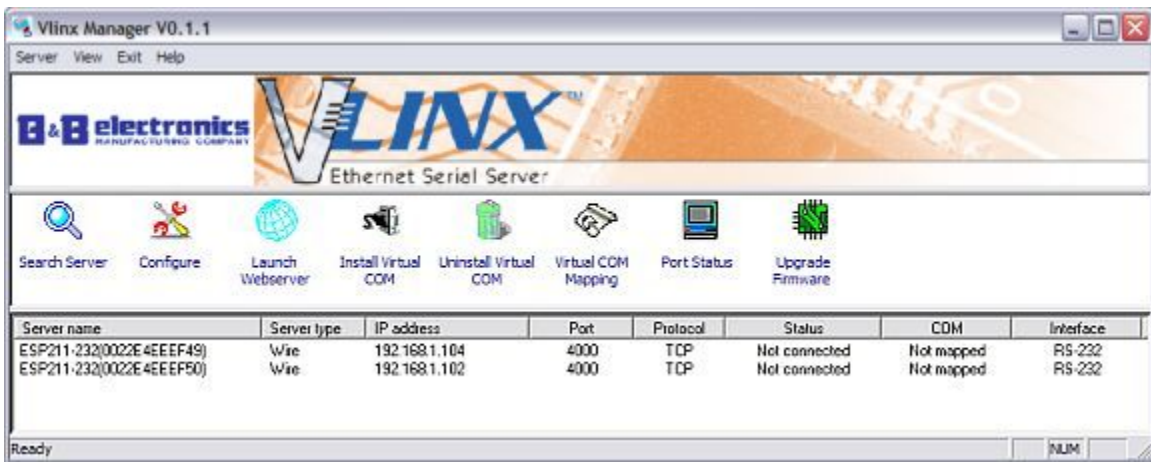

**Figure 6 Vlinx Manager displays all Vlinx Serial Servers found**

With the Vlinx Manager open the software setup is complete.

## 4. Using the Vlinx Manager

The **Vlinx Manager** software allows:

- Searching for servers connected to the network
- Displaying and changing the configuration of those servers
- Installing virtual COM ports on a computer
- Displaying and configuring virtual COM ports
- Uninstalling virtual COM ports on a computer
- Upgrading the Serial Server firmware
- Monitoring Port Status
- Saving and Loading Configuration Files

### 4.1 Hardware Setup

**Step 1:** Connect the Serial Server to the LAN or to a computer Ethernet port.

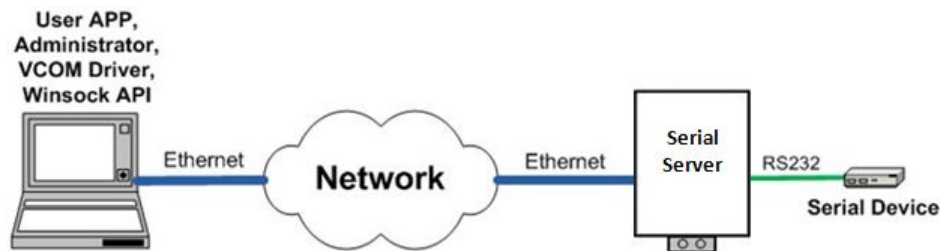

**Figure 7 Ethernet Connection via LAN**

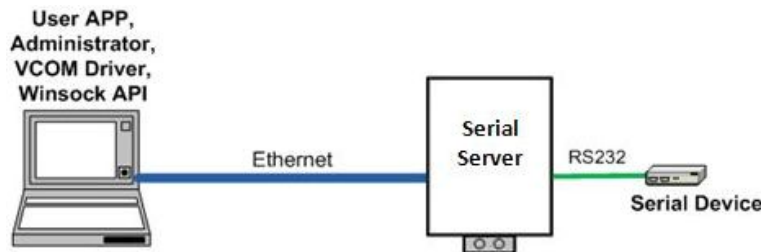

**Figure 8 Direct PC Connection using an Ethernet Cable**

**Step 2:** Apply power, the **Ready** indicator light will flash, and the **Link** indicator on the RJ15 plug lights when an Ethernet connection is made.

### 4.2 Software Setup

**Step 1:** To run the **Vlinx Manager**, from the **Windows Desktop** click:

**Start > Programs > B&B Electronics > Vlinx > Serial Servers > Vlinx Manager**

As soon as the Vlinx Manager opens it will initiate Searching Server and after a few seconds the Serial Server List will display all Serial Server devices on the network.

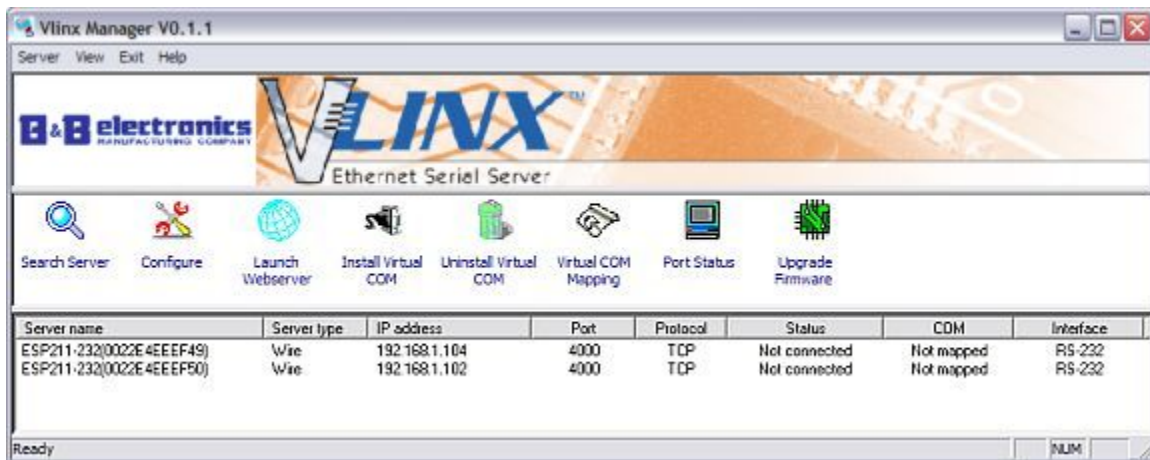

**Figure 9 Vlinx Manager Window**

## 4.3 Software Overview

The **Vlinx Manager** window provides the following information:

- **Menus** (Server, View, Exit, Help)
- **Icons** (Search Server, Virtual COM Mapping, Uninstall Virtual COM, Port Status, Upgrade Firmware, etc.)

### 4.3.1 Menus

#### **Server**

- **Search Server** - Searches for Serial Servers on the network and brings back configuration information that will be displayed in the Server Configurations window.
- **Configure** - Launches a two-screen configuration and reporting interface.
- **Launch Webserver** - Launches a three-screen web-based configuration and reporting interface
- **Install Virtual COM** - Selects the Virtual COM List. Double clicking on any COM port in the Virtual COM List brings up a window that allows changing the virtual COM settings such as Flow Control, Protocol, IP address, and Port Number. Virtual COM settings must match Serial Server port settings.
- **Uninstall Virtual COM** - Allows virtual COM ports to be uninstalled from the Vlinx Manager window.
- **Virtual Com Mapping** – Shows the currently mapped virtual COM ports settings and status.
- **Port Status** - Brings up a screen that displays the following information associated with the serial port:

**Serial TX:** Displays the number of bytes of data sent to the serial device since the IP connection was established.

**Serial RX:** Displays the number of bytes of data received from the connected serial device since the IP connection was established.

**DTR/RTS:** The DTR/RTS Port Status indicator displays the current logic state of the DTR and RTS hardware handshake (output) lines for the selected Serial Server port (1 = asserted, 0 = not asserted).

**DCD/DSR/CTS:** The DCD/DSR/CTS Port Status indicator displays the current logic state being received on the DCD, DSR and CTS hardware handshake (input) lines for the selected Serial Server port (1 = asserted, 0 = not asserted)

**Status:** Indicates whether the client software has made a connection with the Serial Server.

**IP Address:** Displays the IP address of the connected client when there is a client connection

- **Upgrade Firmware** - Used when downloading new firmware to the Serial Server (see Section 8).
- **Save Configuration File** - Allows the user to save the current configuration information to a file with a .vcom extension.
- **Load Configuration File** - Allows the user to load a configuration file.

### View

Provides three viewing options for the **Vlinux Manager** screen:

- **Status Bar** – allows the Status Bar at the bottom of the screen to be viewable or hidden.
- **Split** – allows the position of the split between the Icons pane and the Virtual COM List / IP Serial Server List panes to be dragged horizontally using the mouse.

### Exit

- Exits the Vlinux Manager program

### Help

- Accesses the **About vcomui** (virtual com user interface) dialogue box, which indicates the software version number

## 4.3.2 Icons

The functions **Search Server**, **Configure**, **Launch Webserver**, **Install Virtual COM**, **Uninstall Virtual COM**, **Virtual COM Mapping**, **Port Status** and **Upgrade Firmware** can all be selected with the icons in the top window.

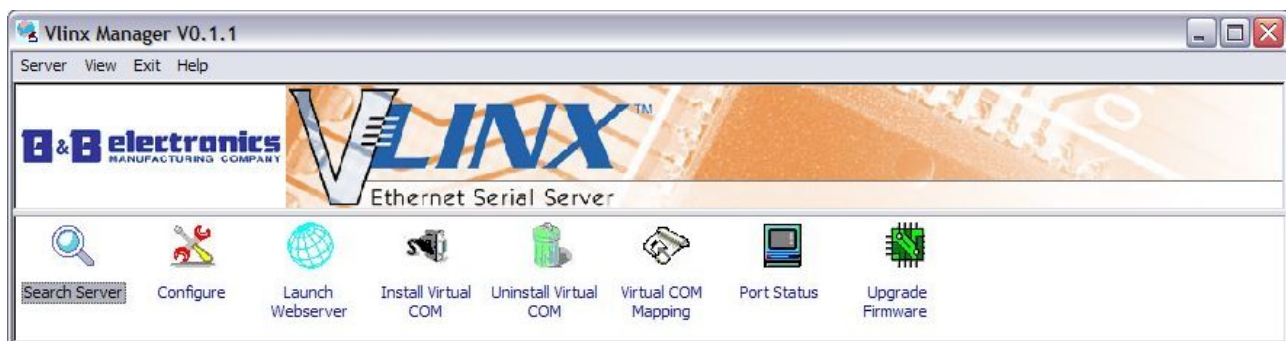

**Figure 10 Vlinux Manager Icon Menu**

### 4.3.3 Serial Server List / Virtual COM List

To make Serial Server list management easier, lists can be sorted by clicking any tab heading. Scroll bars facilitate scrolling through long lists.

#### Serial Server List

- **Server Name** - Displays the name of the Serial Server. The name is listed once for each port.
- **IP Address** - Displays the IP Address for the Serial Server.
- **Protocol** - Displays the currently selected TCP or UDP mode for the Serial Server.
- **Status** - The Status indicates the mapped virtual COM port condition.

**Not Connected** is shown when a program does not have the port Open.

**Connected** is shown when that mapped port is Open for use.

- **COM** - Displays the name of the computer COM port mapped to each Serial Server port. If no computer port is mapped it displays **Not mapped**.
- **Interface** – Displays the interface type of the serial port.

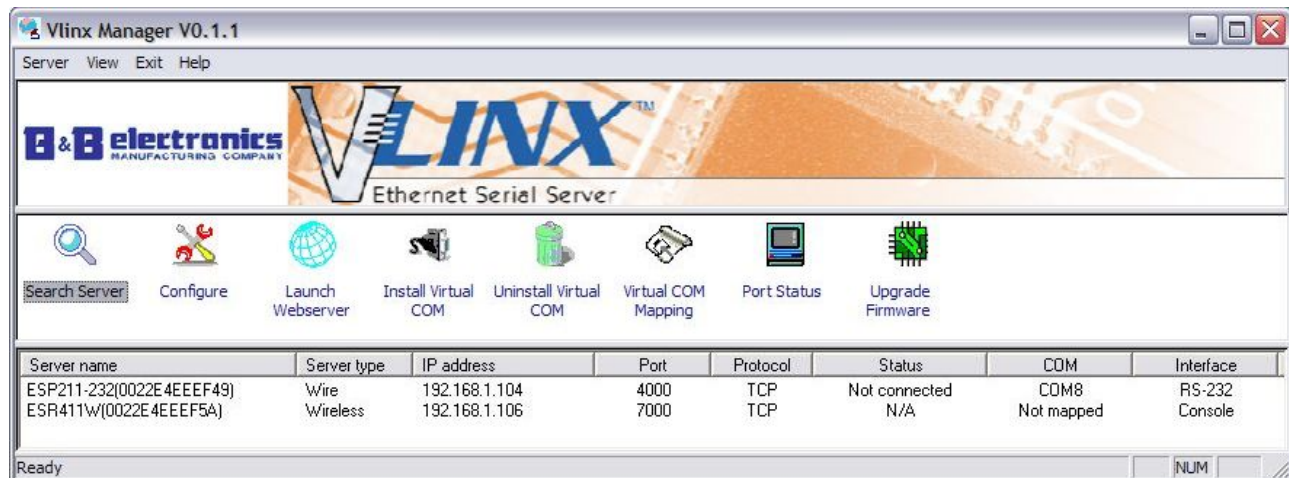

Figure 11 Serial Server List

#### Virtual COM List

Find this list by double clicking on the **Virtual COM Mapping** icon:

- **COM Name** - Displays the number of the COM port mapped to each Serial Server port.
- **IP Address** - Displays the IP Address for the Serial Server. All ports on a Serial Server have the same subnet, and often but not always the same IP address.
- **Protocol** - Displays the currently selected TCP or UDP mode for the Serial Server.
- **Port** - Displays the port number for each Serial Server port.
- **Flow Control** - Shows what type flow control is configured for each port.
- **Status** - Indicates whether ports are currently **In Use** or **Not Used**.

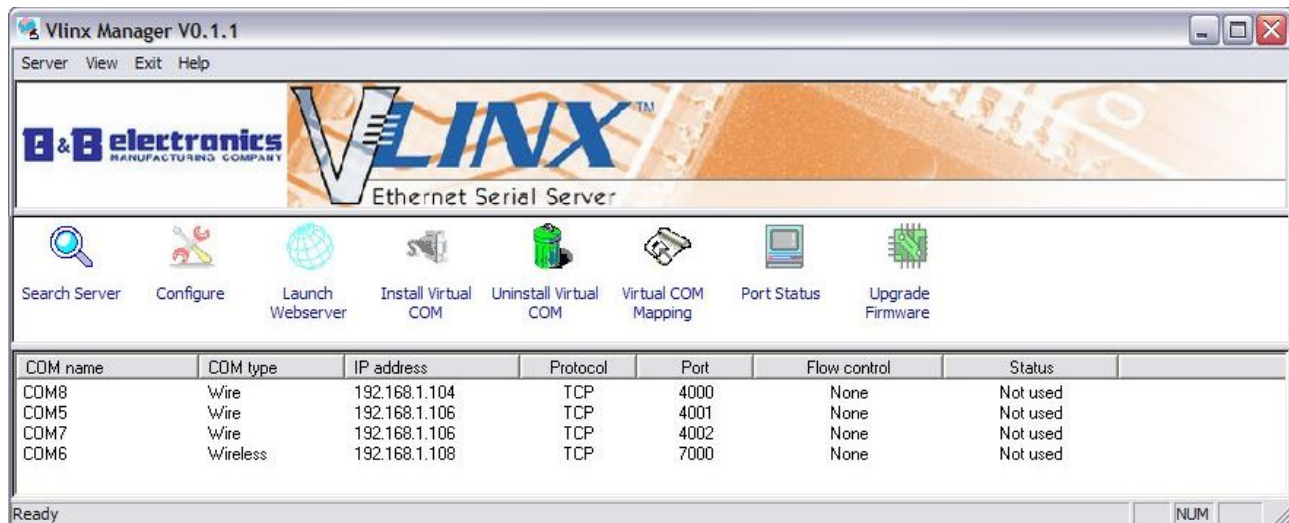

Figure 12 Virtual COM List

#### 4.3.4 Status Bar

Displays the current status of the software in the bottom, left corner of the screen

- Ready
- Waiting for the server to restart...
- Searching reachable servers...

#### 4.4 Search for Servers

Upon opening the Vlinx Manager software it will automatically execute **Search Server** to search for all reachable Serial Servers.

**Step 1:** To manually search for servers, click the **Search Servers** icon. The **Search Setup** box provides two options for searching for servers on the network:

- Specify the IP Address of the Serial Server, or
- Search all reachable servers



Figure 13 Search Setup Window

**Step 2:** Enter the **IP Address** assigned to the desired Serial Server or click **Search all reachable servers**, then **OK**. **IP Address** is used to find Serial Server units that are not on the same subnet. (Routers on the network will block the standard broadcast used to find servers if **Search all reachable servers** is selected.) The user must set an IP address that conforms to the LAN addressing scheme.

The Searching window is shown until all active Serial Servers on the LAN are listed in the **Serial Server List** window.

## 4.5 Setting Configurations

The **Configurations** window displays the current configurations for the currently selected server.

**Step 1:** To open the **Configurations** window, highlight the Serial Server in the **Vlinx Serial Server List** window, double-click to open.

The **Configurations** windows are used to configure and store the configuration settings. Details for setting Configurations are described in the next chapter.

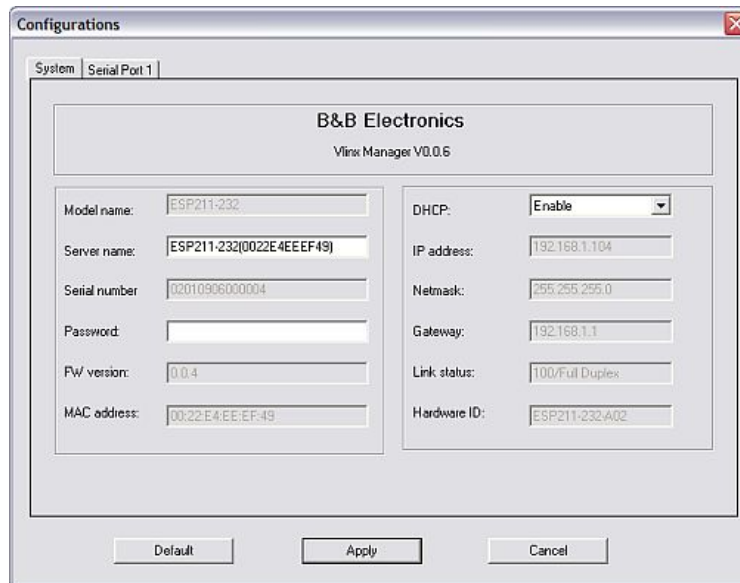

**Figure 14 Configurations Windows**

**Step 2:** After configuring as needed, click **Apply** to store the configuration in the server. The following window will appear:

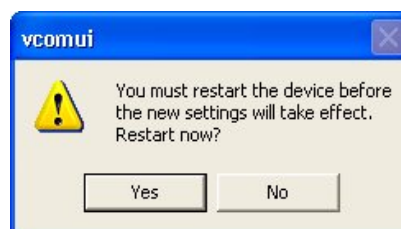

**Figure 15 Restart Dialogue Box**

**Step 3:** Click **Yes** to restart. The following dialogue box will appear:

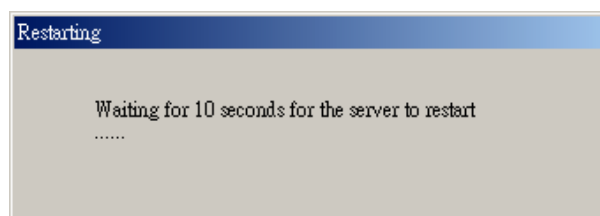

**Figure 16 Restarting Dialogue Box**

After eight seconds a dialogue box will ask whether you want to search for all reachable servers again.

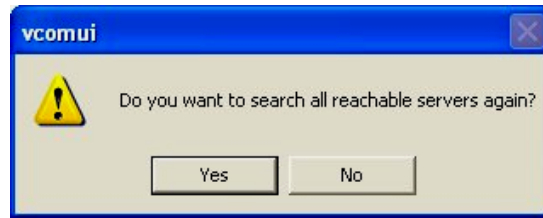

**Figure 17 Search Server Dialogue Box**

While the Serial Server is searching for all reachable servers the following dialogue box appears:



**Figure 18 Searching Dialogue Box**

After that port has been applied you may want to re-enter the **Server Configurations** screens to verify the changes have taken effect.

## 5. Configuring the Vlinux Serial Server

The Serial Server can be configured using any of four different user interfaces: the **Vlinux Manager Software**, **Console Mode**, **Telnet** or the **Web Server**. The **Configurations** described in this chapter can be changed from any of these user interfaces.

### 5.1 Description of Configuration - System

**Figure 19 Server Configurations Window, Vlinux Manager**

#### 5.1.1 Model Name

The model highlighted opens for configuration.

#### 5.1.2 Server Name

This field displays the name that has been assigned to the Serial Server. A new server name with up to 16 characters can be entered. If more than one Serial Server is connected on the LAN it is recommended that a new name be assigned to each. When the Vlinux Manager finds a Serial Server on the LAN it displays the server name and IP Address, to distinguish between Serial Servers.

#### 5.1.3 Serial Number

Each Serial Server has a unique serial number. This is fixed and cannot be changed.

#### 5.1.4 Password

Entering a password activates a security feature on the Serial Server. Once a password is entered it will be required to access the menu and make changes.

#### 5.1.5 FW Version

It shows the currently loaded firmware version.

## 5.1.6 MAC Address

The MAC address is fixed and cannot be changed. It is assigned in the factory. Every Ethernet device manufactured has its own unique MAC address.

## 5.1.7 DHCP

DHCP servers are a part of many LAN management systems. The DHCP field provides two choices: **Disable** and **Enable**. Disable is the default setting. When enabled, the Serial Server will send a DHCP request to the DHCP server, which will assign a dynamic IP address, net mask, and gateway to the Serial Server. If a DHCP server is not available on the network the Serial Server will time out after 10 seconds and the default values will remain. When DHCP is enabled, the IP Address, Netmask and Gateway fields become inaccessible and cannot be changed by the user.

### Note:

A dynamic address assigned by the DHCP server may change if the server loses the Ethernet connection or power is removed. The host (client) communication software requests a connection to the specific IP address of the Serial Server. If the DHCP reassigns a different IP address the software will not be able to communicate with the hardware. Therefore, a fixed IP from DHCP server or using a static IP address is recommended.

## 5.1.8 IP Address

Software or hardware attempting to access the Serial Server via the network must use the IP Address of the server. It is therefore useful to use a static IP address, that remains the same each time the server restarts. The default IP address of the Serial Server is printed on a label on the bottom cover. The network administrator determines the static address or group of addresses to be used.

The IP Address of the Serial Server can be confirmed using the DOS Ping command.

### Notes:

To use Ping to check for communications:

- Access a DOS window (in Win-XP click **Start**, then **Run**)
- At run prompt enter: CMD
- In the DOS window enter: Ping xxx.xxx.xxx.xxx (IP address for the server to be confirmed)
- The command will return the Ping results indicating 4 replies

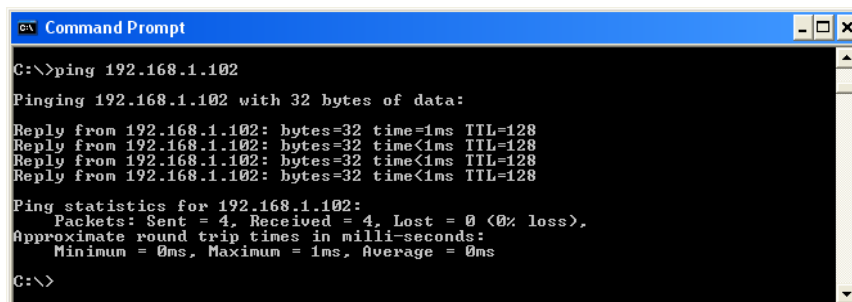

```
Command Prompt
C:\>ping 192.168.1.102
Pinging 192.168.1.102 with 32 bytes of data:
Reply from 192.168.1.102: bytes=32 time<1ms TTL=128
Reply from 192.168.1.102: bytes=32 time<1ms TTL=128
Reply from 192.168.1.102: bytes=32 time<1ms TTL=128
Reply from 192.168.1.102: bytes=32 time<1ms TTL=128
Ping statistics for 192.168.1.102:
    Packets: Sent = 4, Received = 4, Lost = 0 (0% loss),
    Approximate round trip times in milli-seconds:
        Minimum = 0ms, Maximum = 1ms, Average = 0ms
C:\>
```

Figure 20 Pinging using the DOS command window

### 5.1.9 Netmask

The default LAN netmask is configured for a Class C address, and the default is 255.255.255.0. The user may change this.

### 5.1.10 Gateway

The Gateway IP address allows users to access the Serial Server from outside the LAN.

### 5.1.11 Link Status

Link status automatically displays the type of Ethernet connection. It will either display 10BaseT or 100BaseTX in full duplex or half duplex. This will depend on the LAN, switches and hubs used in the LAN topology.

### 5.1.12 Default Mode

Clicking on Default will return all setting, except password, to their factory preset condition.

## 5.2 Description of Configuration – Serial Port

The serial port has a configuration page for easy configuration settings. Click the port to open the configuration page.

**Note:** Changes must be **Applied** (Saved) or the Serial Server will not retain them.

**Figure 21 Port Configuration Screen**

### 5.2.1 Baud Rate

The serial port baud rate on the Serial Server must match the serial baud rate of the connected device unless using Virtual COM Mode. In Virtual COM Mode the software establishes serial settings.

### 5.2.2 Data/Stop bits

Set to match the data format used by the connected serial device.

### 5.2.3 Parity

Set to match the data format used by the connected serial device.

### 5.2.4 Flow Control

Flow Control setting must match the requirements of the connected serial device.

### 5.2.5 TCP/UDP Protocol

Select **TCP** (Transmission Control Protocol) or **UDP** (User Datagram Protocol) protocol.

#### TCP Mode

If the application does not require a UDP connection, select TCP. TCP guarantees reliable communication with error checking; UDP provides faster transmission.

#### UDP Mode

When UDP mode is chosen the **Serial timeout**, **TCP Alive timeout**, **TCP mode**, **Max connection**, **Connection at** and **Remote IP address** fields are replaced with the following fields: **Destination UDP/IP addresses**, **UDP Port**, and **Source UDP/IP addresses**. In this mode the server can be configured to broadcast data to and receive data from multiple IP addresses. Four IP address range fields are provided.

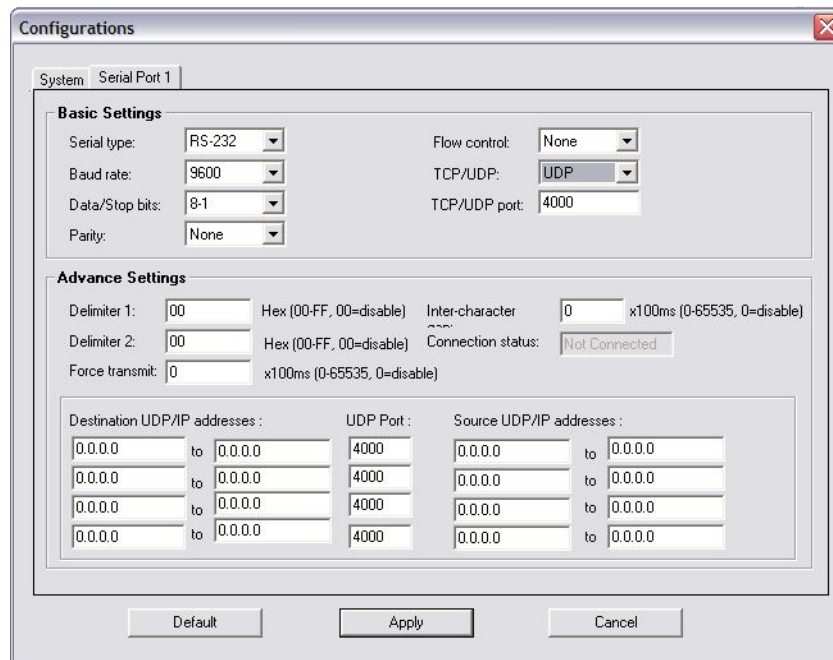

Figure 22 UDP Mode Configuration Screen

#### Notes:

1. **Destination UDP/IP addresses:** In order not to over-flood UDP traffic, keep **Destination UDP/IP addresses** (broadcast range) as small as possible.
2. **Source UDP/IP addresses:** Filters incoming IP/Port, i.e., only accepts UDP packets that come from assigned source addresses.

### 5.2.6 TCP/UDP Port

This sets the port number for each connection. The default port number for the Serial Server is **4000**. In

both **Straight IP** or **Virtual COM modes**, the port number set in the **Server Configurations** menu must match the **Virtual COM** or socket software port settings.

**Example:** The Virtual COM default setting is TCP/UDP Port 4000. If the port # property is changed to another port # such as 4001, the virtual COM port will have to be changed to the same port #. The hardware settings can be changed from the Vlinux Manager, Console Configuration or Webserver menus. The Virtual COM port setting also can be changed from the device manager screen on the computer on which it is installed, but if these settings are changed in the Device Manager, it will only affect the operation of the virtual COM port. It will not change the settings stored in the Serial Server. Use the **Vlinux Manager** to change the Serial Server settings.

### 5.2.7 Delimiter Hex 1 and Delimiter Hex 2

These fields allow the user to enter two ASCII characters (in hex format) that delimit the beginning and end of a message. When a message with both these delimiters is received at the serial port, the data contained in the serial buffer is placed in an Ethernet packet and sent out the Ethernet port. If only Delimiter 1 is set (Delimiter 2 is zero or blank), upon receiving Delimiter 1 the Serial Server will put all the data in the serial buffer in an Ethernet packet and send it out through the Ethernet port. If serial data greater than 1 kilobyte is received it will automatically be placed in an Ethernet packet and sent out through the Ethernet port.

### 5.2.8 Force Transmit

This field allows the user to set a maximum time limit between transmissions of data. The value set in this field, multiplied by 100 ms, determines the Force Transmit time. When elapsed time reaches the time configured in this field, the TCP/IP protocol will pack the data currently in the serial buffer into a packet and send it out the Ethernet port.

### 5.2.9 Inter-character Gap

The Inter-character timer defines the maximum time allowed to elapse since last data byte was received, without being sent.

When inter-character timer maximum is reached, the TCP/IP protocol packs the data currently in the serial buffer into a packet and sends it out through the Ethernet port.

### 5.2.10 Connection Status

This field indicates whether the serial port is connected via the Serial Server to a virtual COM port of a device on the network.

### 5.2.11 Serial Type

Each Serial Port allows configuration to one of the following operation modes:

#### 5.2.11.1 RS-232

**Port 1**, the only serial port, is set by default to **RS-232** mode.

In RS-232 Mode the current selected serial port is configured as an RS-232 interface. It supports eight RS-232 signal lines plus signal ground, and is configured as a DTE, much like a computer. Signals are single ended and referenced to ground. To use handshaking, flow control must be set to RTS/CTS during configuration.

### 5.2.11.2 Console Mode

The **Serial Port** can be reset to **Console** mode. This can be done in any of three ways:

- From Vlinx Configuration Software (requires that a connection through an Ethernet port established)
- Through Webserver (requires that a connection through an Ethernet port be established)
- By connecting the RS-232 serial port of a PC to the Serial Server Serial Port 1 through a null modem crossover cable (because the computer is a DTE device with DB-9M connectors) and powering up the unit while pressing the **Shift** and **~** keys in your computer keyboard together till the council screen is displayed (usually takes about 10 sec.). This method is also the alternate method to configure a Serial Server in case the Ethernet connection cannot be established.

In Console mode, the Serial Server Configuration Menu can be accessed and configured through the serial port.

In Console Mode the default serial port settings are: **9600** baud, **8** data bits, **1** stop bit, and **No** parity. From Windows, a VT100 terminal emulation program (such **HyperTerminal** or **PuTTY**) can be used for Console Mode configuration.

In the Vlinx Manager Serial Port 1 configuration screen, hit the Space bar and you will see the console screen showing up.

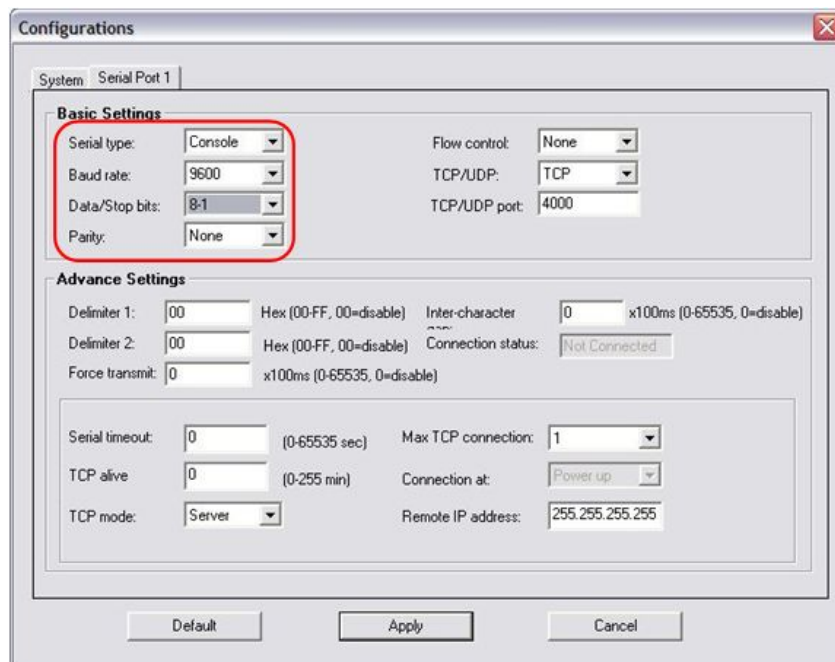
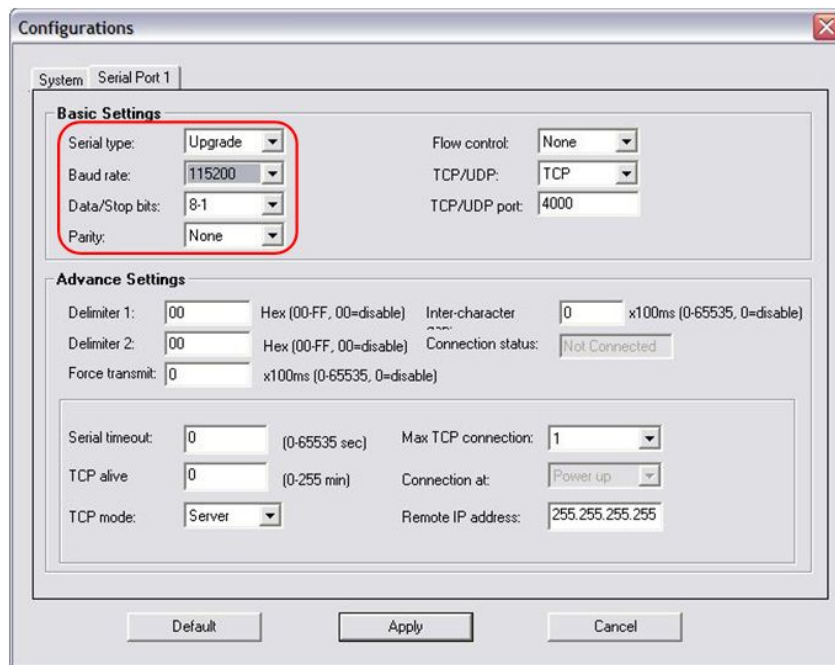

**Figure 23 Console Mode Configuration Screen**

### 5.2.11.3 Upgrade Mode

In upgrade mode, firmware can be uploaded from a PC via its serial port to the Serial Server **serial port 1**. Upgrading also can be accomplished through the network connection, by using the Vlinx Manager software and a virtual COM port.

In upgrade mode the default serial port settings are 9600 baud, 8 data bits, no parity and 1 stop bit. However, baud rate can be reconfigured up to **115200** bps to facilitate faster uploads.



**Figure 24 Upgrade Mode Configuration Screen**

### 5.2.12 Serial Timeout

Default for the timeout property is 0, or no timeout. This is activated by resetting the value between 1 and 65535 seconds. If the timeout value is set to 5 seconds and the Serial Server is configured as a **Server**, when the **Client** makes connection and communication starts, then communication stops for 5 or more seconds, the Serial Server closes the TCP session and becomes available for another client connection request.

### 5.2.13 TCP Alive Timeout

The "TCP keep-alive" function replaces the "TCP alive timeout" function. Effective in server mode only, this field can be set to any value between 0 and 255 minutes. Value 0 disables the function.

If enabled, the unit queries the client regularly. If the client fails to respond in the "TCP alive timeout" period, the Serial Server closes the TCP session to prevent TCP connection lockup. This is especially useful for the WINSOCK application, as the Serial Server won't be deadlocked when user's application closes improperly or the network link is interrupted.

**Note:** The TCP **Probe** function is for VCOM, not the WINSOCK application.

### 5.2.14 TCP Mode

The Connection Mode field has three options: **Server**, **Client** and **Client (no Probe)**. When **Client** or **Client (no Probe)** is selected the **Connection at** field automatically becomes active (allowing the user to select **Power up** or **Data Arrival**):

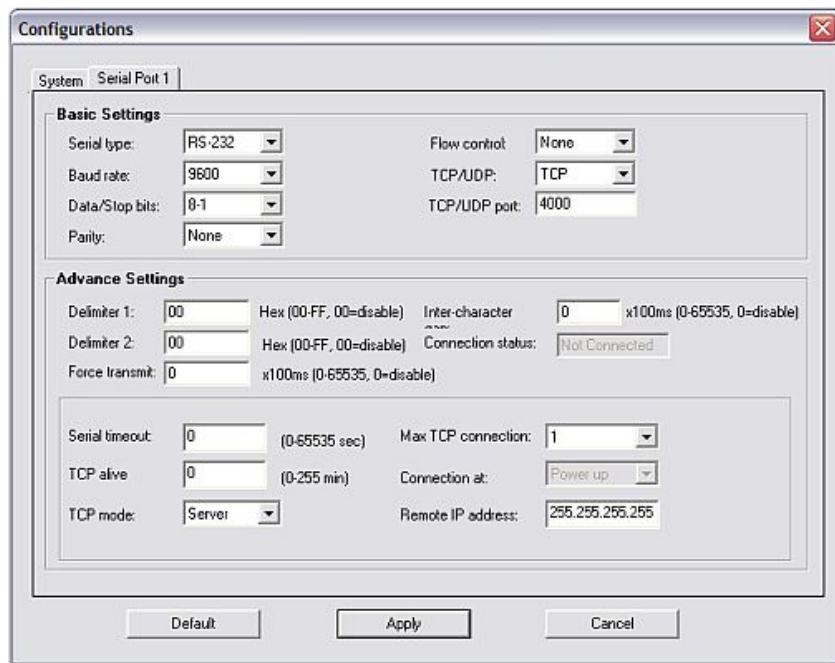

**Figure 25 TCP Mode Configuration Screen**

- When using the **Virtual COM Port** feature, select **Server**.
- When using a **TCP** or **UDP Socket** program, select **Server**.
- When using **Paired Mode** communication between two **Vlinx Serial Servers**, set up one as a **Client** and the other as a **Server**.
- When connecting to a server that does not support **Probe**, select **Client (no Probe)**.

### 5.2.15 Max Connection

This allows the user to configure the Serial Server to have up to **eight** TCP connections.

### 5.2.16 Connection At

When the **Connection Mode** field is set to **Client** or **Client (no Probe)**, this field becomes active, allowing the Serial Server (acting as a client) to connect to the server either on **Power up** or on **Data Arrival** (first character arriving).

### 5.2.17 Remote IP Address

This is a security feature activated by entering the IP address of the desired client. The Serial Server will only communicate with the listed IP address and reject all others.

Default setting is **255.255.255.255.**, which disables the filter function and passes all TCP packets.

### 5.2.18 Apply

Server configurations must be applied saved for the serial port.

#### 5.2.18.1 Saving Configuration Data in Vlinx Manager

From the **Configurations** screen, click the **Apply** button to store the configuration settings for the currently selected port. The vcomui (Vcom User Interface) dialogue box appears, indicating to restart the device before the new settings will take effect. Click **Yes**.

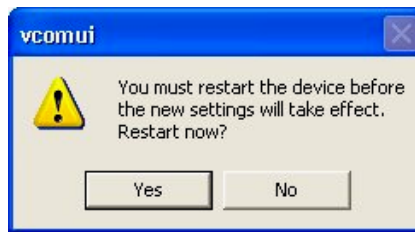

**Figure 26 Restart Dialogue Box**

After the port has been applied you may re-enter **Configurations** to verify the changes have taken effect.

### 5.2.18.2 Saving Configuration Data in Console Mode or Telnet

Saving Server Configurations is done from the **Properties** screen. Access the **Properties** screen by tabbing through the **Page list** of screens on the left side of the window and highlighting **Apply**.

There are four options shown on the right side of the **Properties** screen: **Apply**, **Default**, **Reload** and **Restart**. Use **Tab**, **Backspace**, or **arrow** keys to move the cursor to choose the correct option, then press **Enter**.

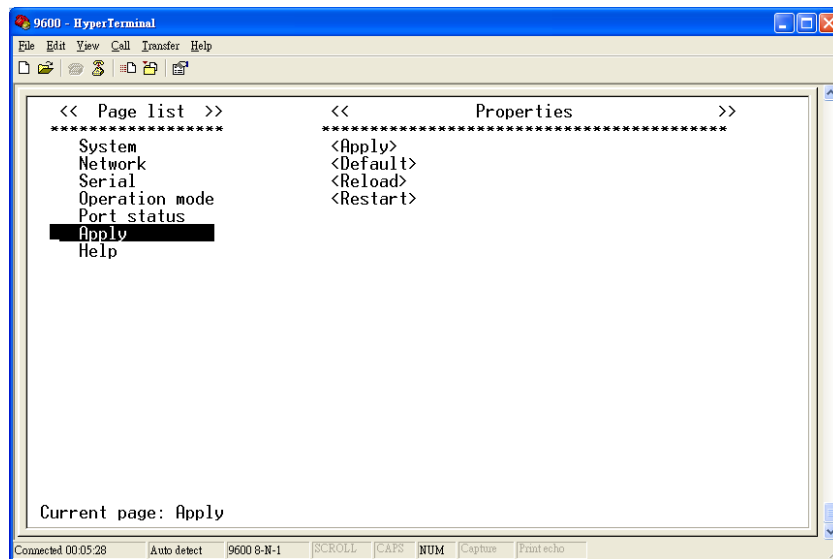
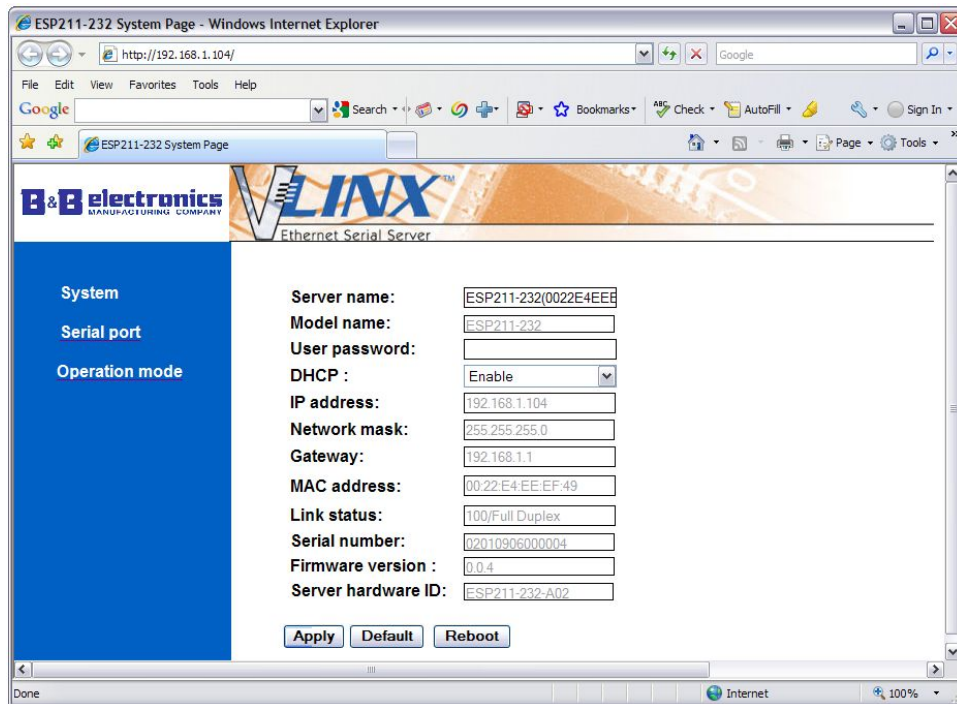

**Figure 27 Console Configuration Window**

- **Apply** -- stores the configuration data to the Serial Server flash memory and resets it.
- **Default** -- restores the configuration data to factory default settings.
- **Reload** -- restores the configuration data to the last values stored in the flash memory.
- **Resart** -- re-boots the Serial Server, making it available for a client connection.

### 5.2.18.3 Saving Configuration Data in Web Server Interface

**The Web Server interface provides the same viewing and updating options as Console Mode and Telnet. These are located at the bottom of Web Server page. If a field is changed, you must click Apply before leaving that page or the changes will be ignored.**



**Figure 28 Web Server Configuration**

## 6. Installing Virtual COM Ports

The **Virtual COM Port** feature allows Windows platform software, using standard API calls, to be used in an Ethernet application.

The **Install Virtual COM Port** software adds a Serial Server (COM#) port to the computer. This shows up in the **Device Manager**. The COM number can be selected from a list of available port numbers. For example, in a computer already having a COM1 and COM2, COM3 to COM 254 are available for the Serial Server. It is recommended that COM Port 5 or higher be selected. The virtual COM port looks like a standard COM port to most Windows based applications, which allows the software to open a connection with the serial port located anywhere on the LAN/WAN. When using the virtual COM port the Serial Server is configured as a TCP or UDP Server.

### 6.1 Installing Virtual COM Port

From the **Vlinux Manager**, click select appropriate server and click **Install Virtual COM**:

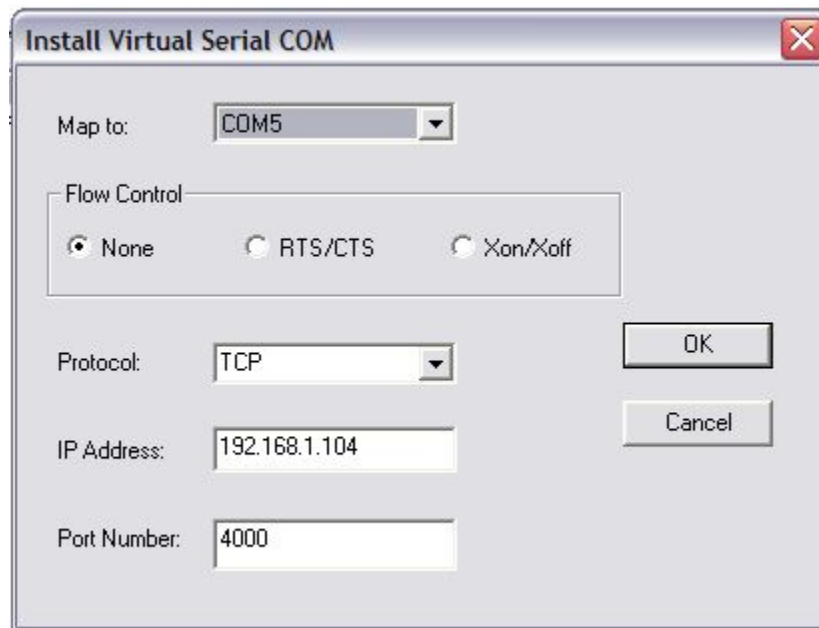

**Figure 29 COMInst Window**

The Protocol TCP/UDP, IP Address, and Port Number will mirror the settings of the selected Serial Server.

Map to COM 5 or higher.

The default **Flow Control** setting is **None**. RTS/CTS can be selected if used by the application program and serial hardware. The Serial Server must be set to match.

### 6.2 Matching the Serial Server and Virtual COM Port Settings

The settings of the virtual COM ports in the **Device Manager** and the Serial Server **Configuration Menu** must match. If the settings do not match, virtual COM ports will not work. If these settings are changed in the **Device Manager**, it will only affect the operation of the virtual COM port. It will not change the settings stored in the Serial Server. Use the **Vlinux Manager** to change the Serial Server settings.

**Step 1:** Use Windows Device Manager to view new ports. Confirm the virtual COM ports in the Device Manager.

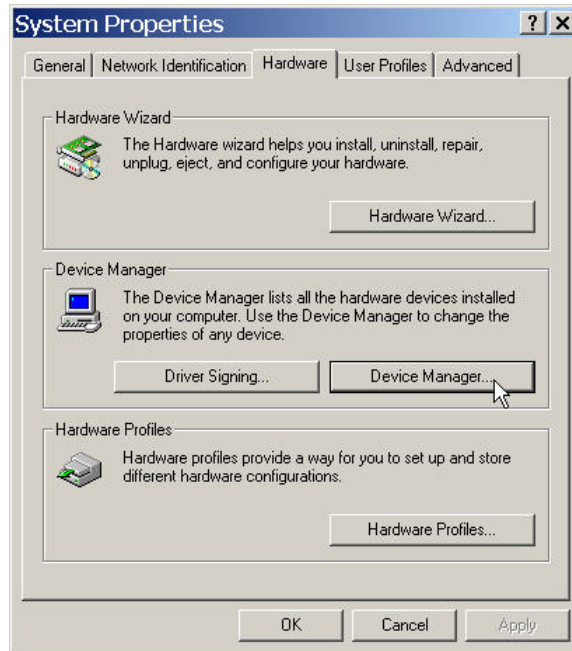

**Figure 30 System Properties Window**

**Step 2:** Double-click **Ports** to view the list of COM port numbers.

The installed Virtual COM port will be displayed as Serial Server (COM #).

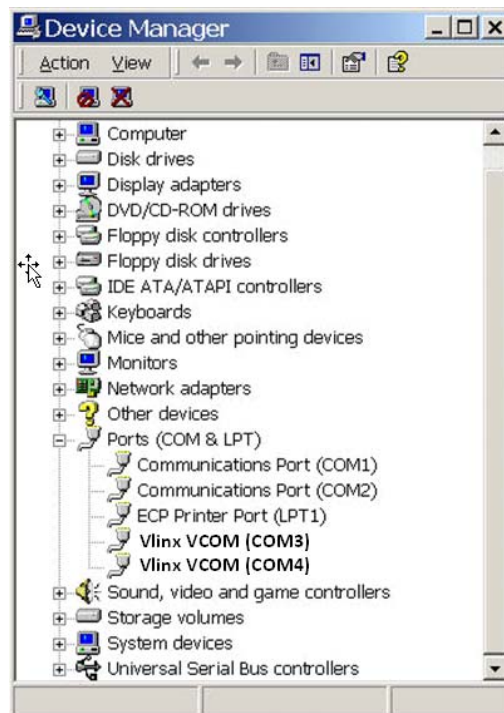

**Figure 31 Device Manager Window**

**Step 3:** In the Device Manager select the Serial Server (**COM #**). Double-click it to bring up the **Properties** window.

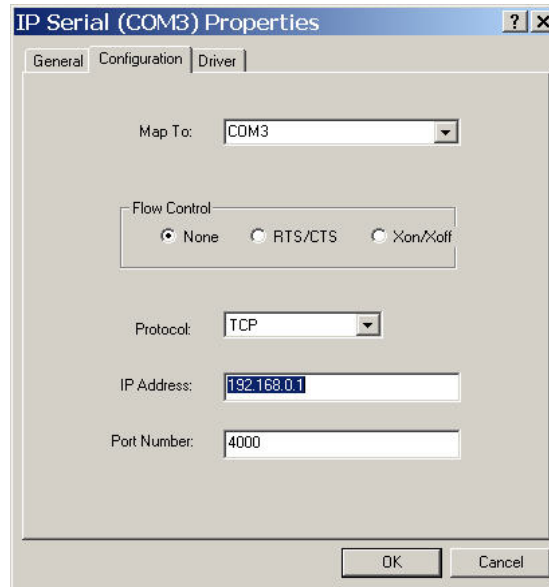

**Figure 32 Virtual COM Port Configuration Window**

**Step 4:** Click the **Configuration** or **Port Settings** tab. This screen allows the settings to be changed if necessary. Click **Cancel** to keep the existing settings.

**Step 5:** Click **OK** to change the settings. Use **Refresh** in the Device Manager if Windows does not auto refresh.

## 7. Removing Virtual COM Ports

The **Vlinux Manager** software **Uninstall Virtual COM Port** feature will remove a mapped COM port in the Device Manager of Windows 2000/2003/ XP/Vista operating systems.

### 7.1 Removing the Virtual COM port using Vlinux Manager

**Step 1:** From the Windows Desktop, click:

**Start > All Programs > Serial Server > Vlinux Manager**

**Step 2:** In the **Vlinux Manager** window, click the **Virtual COM Mapping** icon. Highlight the mapped COM port number to be removed.

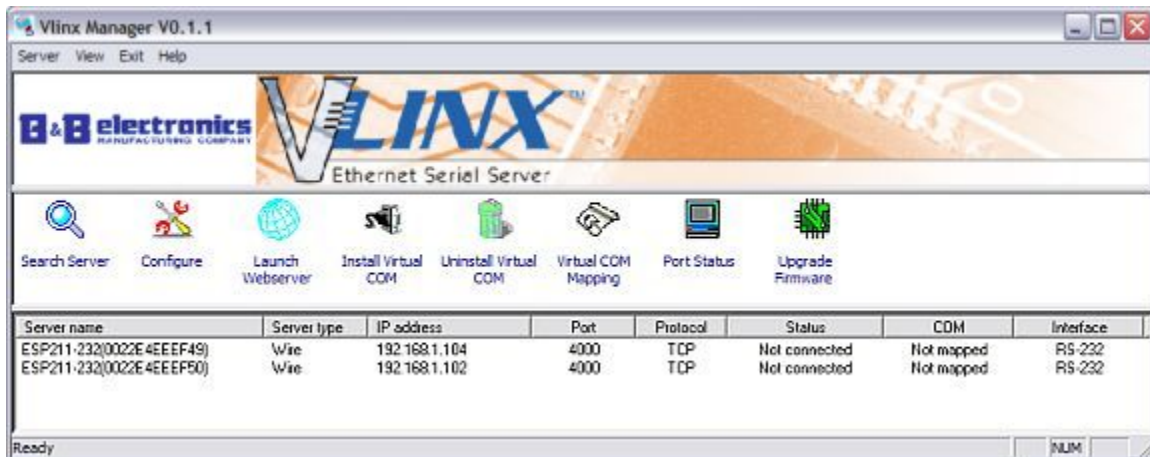

**Figure 33 Vlinux Manager Window**

**Step 3:** Click the **Uninstall Virtual COM** icon. The Administrator will ask for conformation. Click **OK** to complete the uninstall procedure.

### 7.2 Removing the Virtual COM Port using Device Manager

**Step 1:** From the Windows **Desktop** click:

**Start > Settings > Control Panel**

**Step 2:** Click the **System** icon.

**Step 3:** Click **Device Manager** in the **System Properties** window. In the Device Manager dialogue click the + next to **Ports (COM & LPT)** to expand.

**Step 4:** Highlight Serial Server com port (**Vlinux (COM#)**) to be removed and click the **Action** tab at the top of window, then click **Uninstall**. A confirm **Device Removal** window will appear.

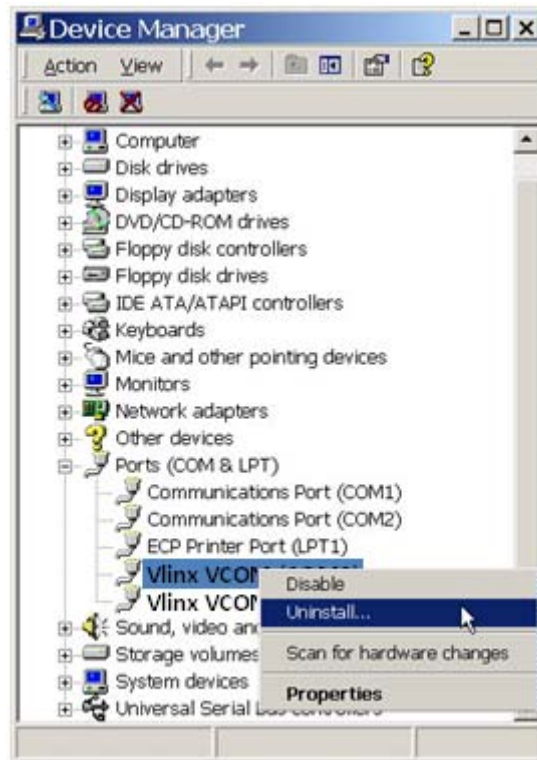

**Figure 34 Confirm Device Removal Window**

**Step 5:** click **OK** to proceed.

The Serial Server virtual com port (**Vlinux (COM#)**) will be removed and the Device Manager window will refresh and display the remaining virtual COM ports.

## 8. Upgrading the Vlinx Serial Server Firmware

New Vlinx Serial Server firmware updates may become available through the website for installation on the server. The firmware can be uploaded using either a virtual COM port connection or hardware COM port connection.

The **Vlinx Manager** software can upload new firmware to the server using a direct PC connection via the Serial Server port or using a virtual COM port.

### Notes:

1. Have a folder to hold the firmware file that will be uploaded to the ESP211-232.
2. If connecting directly to a computer serial port, use a null modem cable between the computer RS-232 port and the Serial Server serial **port**.

### 8.1.1 Change to Upgrade Mode

**Step 1:** In the **Vlinx Manager, Vlinx Serial Server List** window, double click the server to be upgraded. The **Configurations** window will appear.

**Step 2:** If using a direct connection to upload the firmware to the Serial Server, set the baud rate to **115200** for the fastest possible upload.

**Step 3:** Set the **Serial type** field to **Upgrade** and click the **Apply** button.

**Step 4:** Click **Yes** on the **vcomui** (VCom User Interface) dialogue to restart the Serial Server.

### 8.1.2 Upgrading the Firmware

**Step 5:** Double-click the **Upgrade Firmware** icon.

**Step 6:** In the **Upgrade** window, click **Browse**. The **Open** dialogue box will appear. Locate the folder on your PC that contains the firmware .hex file. **Select** the file and click **Open**. The Open dialogue box will disappear.

**Step 7:** In the **Upgrade** window select the serial port to be used in transferring the firmware. If using a virtual COM port, identify the virtual COM number and address mapped to Port 1 on the Serial Server.

**Step 8:** Click **Upgrade**

**Step 9:** In the **Port Settings** window set the **Bits per second, Data bits, Parity** and **Stop bits** to the same values as set up in the **Configurations** window. Click **OK**.

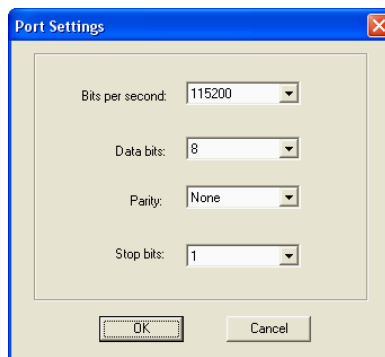

**Figure 35 Port Settings Window**

**Step 10: Upgrade progress** will be shown until the message **Upgrade finished!** is shown. Click **OK**.

## 9. Using Console Mode

Before the Serial Server is installed on a LAN the **Console** mode can be used to change the settings from the defaults. The Serial Server is shipped with **Serial type** in **RS-232** mode. Connect a crossover (null modem) cable between the COM port on the computer and the **serial port 1** on the Serial Server.

### 9.1 Entering Console Mode

**Enter Console mode via Vlinx Manager (requires Ethernet connection):**

1. Enter the **Vlinx Manager**, open the Server Configurations, and set the serial **port 1** to **9600** baud and 8-N-1. Set the **Serial type** to **Console**.
2. Click **Apply** to take effect the settings.

**Enter Console mode via Web Page (requires Ethernet connection):**

1. Use Internet Browser that comes up to log in Web server.
2. Enter the **Serial port** page, set the **Serial type** to **Console**.
3. Click **Apply**, and then **Reboot**

**Enter Console mode via Serial Port (Configuration method when Ethernet connection to the server could not be established)**

1. Disconnect the power and connect a serial RS-232 cable from the ESP port 1 to your computer's COM port (use a null modem or crossover cable as needed).
2. Open a terminal emulation program (such as **HyperTerminal** or **PuTTY**) and connect to the COM port in step #1. Set the baudrate to 9600, 8 data bits, no parity, 1 stop bit and no flow control.
3. Press and hold the “~” key while powering-up the ESP and release the key once READY LED starts blinking (usually within 5-10 sec).
4. When the ESP finishes startup (READY LED will blink once per second), the ESP serial port 1 will be automatically set to console mode.
5. Hit the Space bar you will see the console screen showing up.

### 9.2 Console Mode Setup

**Step 1:** Apply power to the Serial Server. The power and ready LED will light.

**Step 2:** Using a VT100 Terminal emulation program (such **HyperTerminal** or **PuTTY**) open the computer COM port connected to the Serial Server (via an RS-232 crossover / null modem cable).

**Step 3:** Configure a terminal emulation program with the following settings:

- Baudrate = 9600
- Data/stop bits = 8-1
- Parity = none
- Flow control = none

Click **OK**

**Step 4:** Enter the Console mode via Vlinx Manager or Web page.

**Step 5:** To view the **Configuration Menu**, press the **space bar**. The menu will appear in a second.

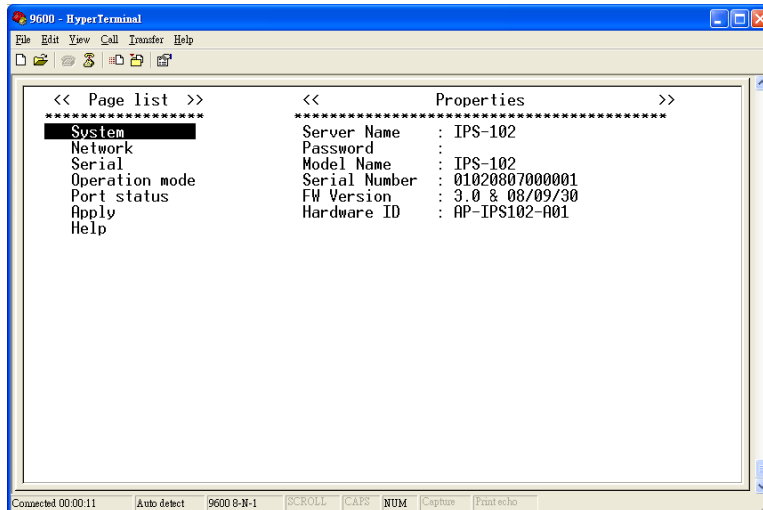

**Figure 36 Console Mode Screen in the HyperTerminal Window**

**Note !!!** Please set the Emulation type to VT100 mode in your Terminal Emulation Program (e.g., HyperTerminal) or simply use PuTTY (select serial mode), so the left arrow & right arrow keys will function.

### 9.2.1 Navigating the Configuration Menus

There are six **Console Mode** pages: **System**, **Network**, **Serial**, **Operation mode**, **Port status**, **Apply**, and **Help**. **Tab**, **Back Space** and **arrow** keys can be used to highlight the desired item on the screen list. Pressing **Enter** moves the cursor to the first field of the current screen. The configuration fields can be changed by pressing **Enter** and selecting from the list that appears. The **Esc** key moves the cursor back to the screen list. Pressing the **Space Bar** refreshes the page.

**Step 6:** Once all the changes have been made move to the **Apply** page and **Enter**, select **Apply** and press **Enter**.

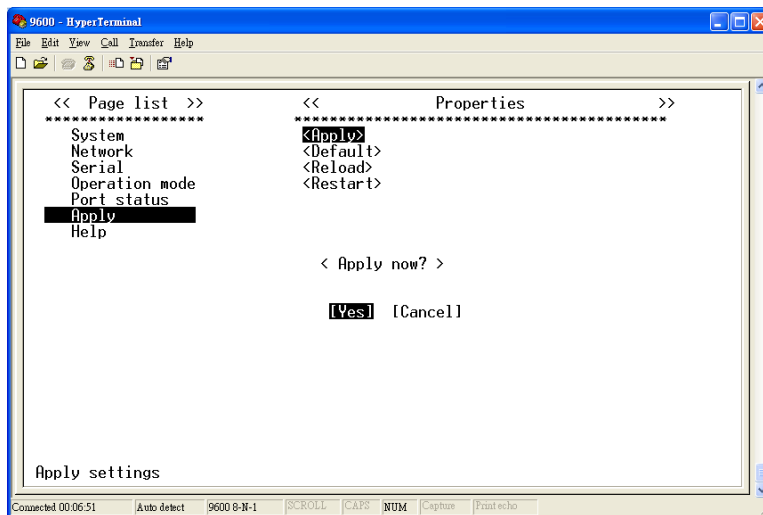

**Figure 37 Saving and Restarting the Configuration in Console mode**

The restart message will appear.

**Step 7:** Select **Yes** to save changes.

## 10. Using the Web Server

The Web Server can be used to configure the Serial Server from any web browser software (such as Internet Explorer). Server Configurations can be set up using three browser pages.

### 10.1 Setting Server Configurations

In Internet Explorer type the IP Address of the Serial Server into the address field near the top of the window and press the **Enter** key. The **General Settings** window will appear:

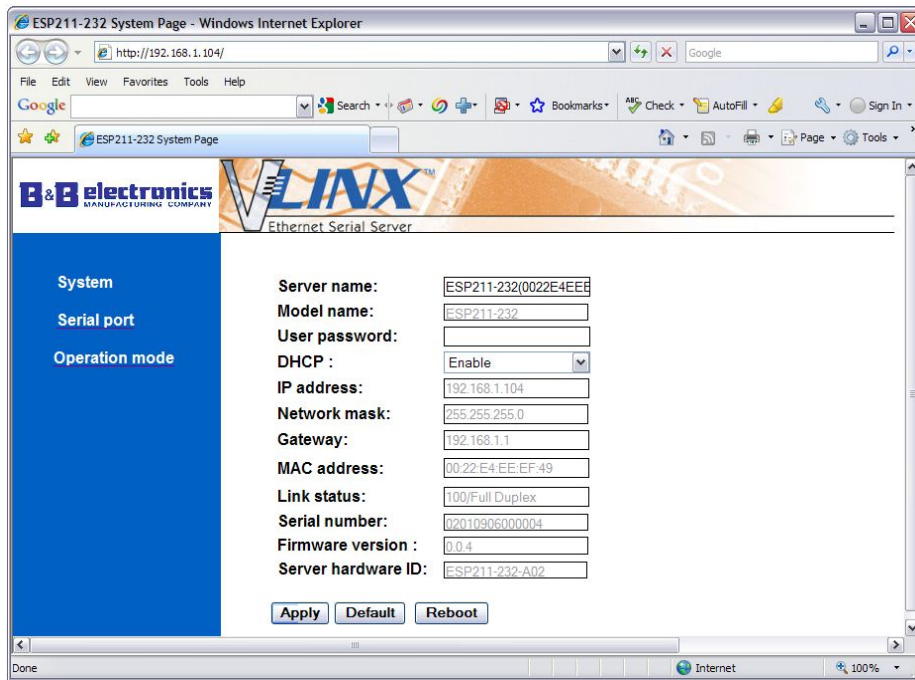

**Figure 38 Web Server – System Page**

Navigate and change Configurations as required using the mouse and keyboard.

To change serial port Configurations, click **Serial Port** on the left side of the browser window. The following page will appear:

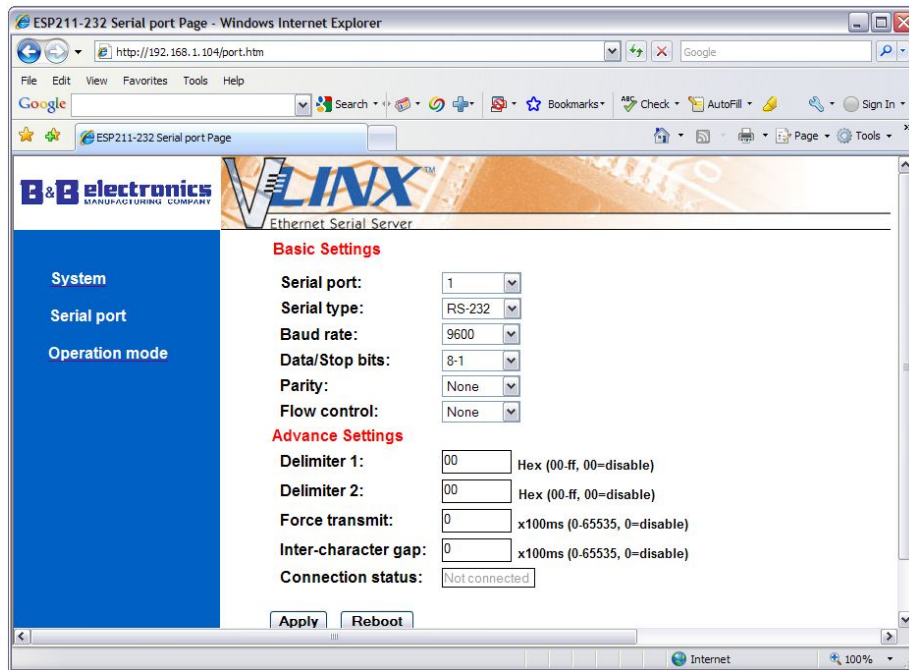

Figure 39 Web Server Serial Port Configurations Page

To change other operational Configurations, click **Operation Mode** on the left side of the browser window. The following page will appear:

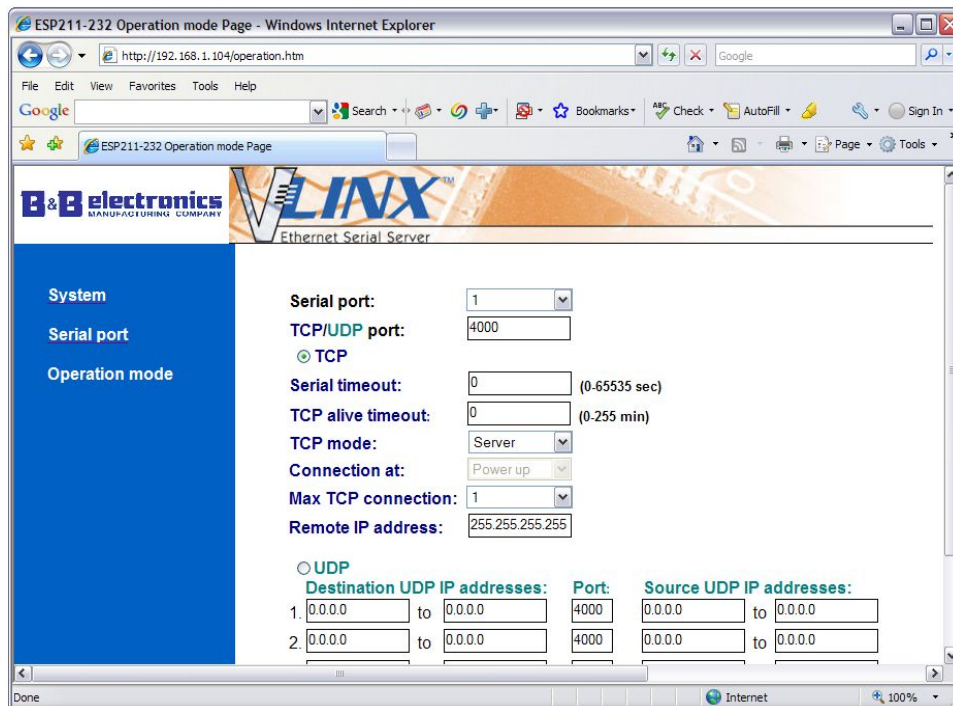

Figure 40 Web Server Operation Mode Configuration Page

Click **Apply** to store changes to the Serial Server. Settings for each Port must be saved separately.

**Note:** If you leave any Web Server page without **Apply** (saving), any changes you have made in this page will be ignored.

## 11. Using Telnet

A Telnet client can be used to configure the Serial Server from the LAN. The Telnet window displays the same configuration information shown in Console Mode and allows Server Configurations to be configured. Basically, the configuration interface of Console mode and Telnet are the same, except that Telnet is remote login.

### 11.1 Telnet Login

**Step 1:** Ensure the PC and the Serial Server are connected to the LAN.

**Step 2:** Apply power to the Serial Server. The power and ready LED will light.

**Step 3:** From the **Desktop**, click **Start**, and then **Run**. The Run dialogue box will open.

**Step 4:** Type in **Telnet** and the IP address of the Serial Server to be configured, and then click **OK**.

**Step 5:** The **Telnet** window will open and the **Server** screen will appear.

**Note:** The Serial Server must be in RS-232, **and must not be in Console mode**, before you can use Telnet to access the configuration screens.

### 11.2 Navigating the Configuration Menu

There are six **Console Mode** pages: **System**, **Network**, **Serial**, **Operation mode**, **Port status**, **Apply**, and **Help**. **Tab**, **Back Space** and **arrow** keys can be used to highlight the desired item on the screen list. Pressing **Enter** moves the cursor to the first field of the current screen. The configuration fields can be changed by pressing **Enter** and selecting from the list that appears. The **Esc** key moves the cursor back to the screen list. Pressing the **Space Bar** refreshes the page.

**Step 6:** Once all the changes have been made move to the **Apply** page and **Enter**, select **Apply** and press **Enter**.

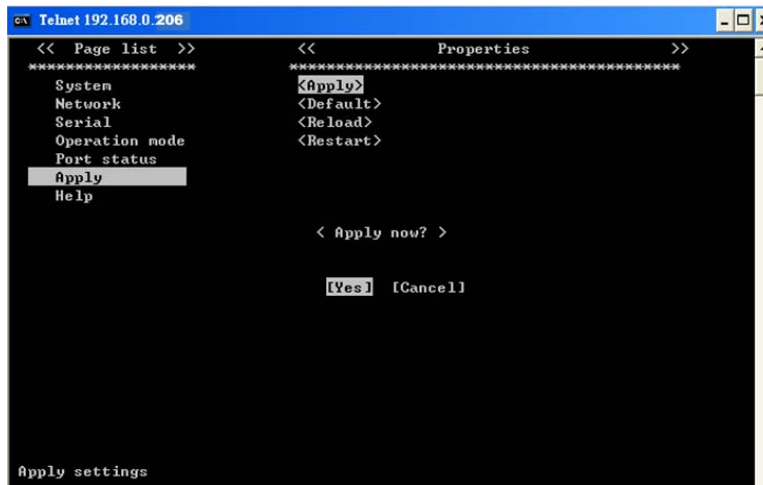

**Figure 41 Saving and Restarting the Configuration**

The restart message will appear.

**Step 7:** Select **Yes** to save changes.

## 12. Operation Modes

By using Vlinx 211-232 Serial Servers, serial RS-232 devices are no longer limited to a physical connection through a PC COM port. They can be linked anywhere an Ethernet connection is possible, and without any changes to serial network software. This allows Windows PC's to access serial devices anywhere a wired or wireless connection can reach.

Many functions that used to require on-site maintenance can now be handled from a central office. Gathering data, configuring systems and devices, even verifying correct operation and troubleshooting problems, can be done from anywhere in the world. And access is restricted to only those who need it.

Upgrades to Ethernet hardware and software don't require changes to sensor and control applications, because the transmitting medium is invisible to the serial network. Changes to serial equipment and protocols also don't impact Ethernet configurations.

Serial Servers are simply miniature but real computers. The sole function of these is to interpret and transmit data to and from Ethernet and serial devices and formats. They also allow engineers to combine the simplicity, proven dependability and cost effectiveness of serial technology with the open protocols and reach of the Ethernet/Internet world.

Here are the most commonly used modes, plus a few tips on making things run smoothly.

***\*Please Note: IP addresses given are examples only. You must verify the actual IP addresses in your setting to determine the correct ones to use.***

### 12.1 Straight IP Mode

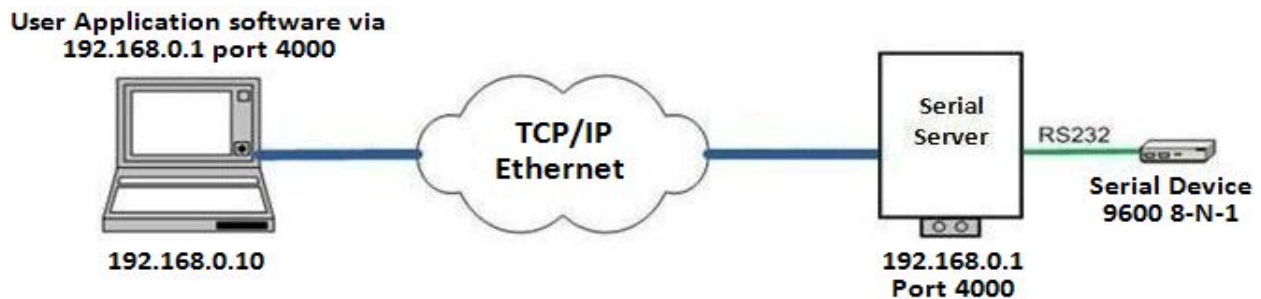

Direct IP connections allow applications using TCP/IP socket programs to communicate directly with serial ports on the Ethernet Serial Server. The TCP format running on the PC establishes a connection with the serial server's IP address.

Direct IP mode is the default operations mode for Vlinx™ Serial Servers. It is basis for the well understood network protocols most used in many settings. Screens, tasks and processes will feel intuitive, since they are grounded in tech's experience with the Internet and PC's.

Since direct IP technology isn't limited to the Windows operating system, it offers the greatest potential flexibility as interfaces can be developed for Linux, Mac – even DOS or any other computer system that runs TCP software. Some potential RS-232 applications that have greatly extended reach with the Serial Server are:

- Digital measurement devices (scales, etc.)
- Fax / Modems
- Control of hardware devices

### GUI Configuration:

1. Connect the PC to the Serial Server using the Ethernet port and connect the serial device using a serial cable (or cross-over cable as needed).
2. Setup software and search for the Server using Vlinx Manager.
3. Double click on the device to open Configurations screens.
4. Note the IP address of 192.168.0.1\* of the Server on the “System” page.
5. Click on “Serial Port 1” page and configure the unit Basic Settings to match serial device like 9600 8-N-1.
6. Note the “TCP/UDP port” = 4000.
7. Note the “TCP mode” = server (for Direct IP mode).
8. Save settings and reboot.

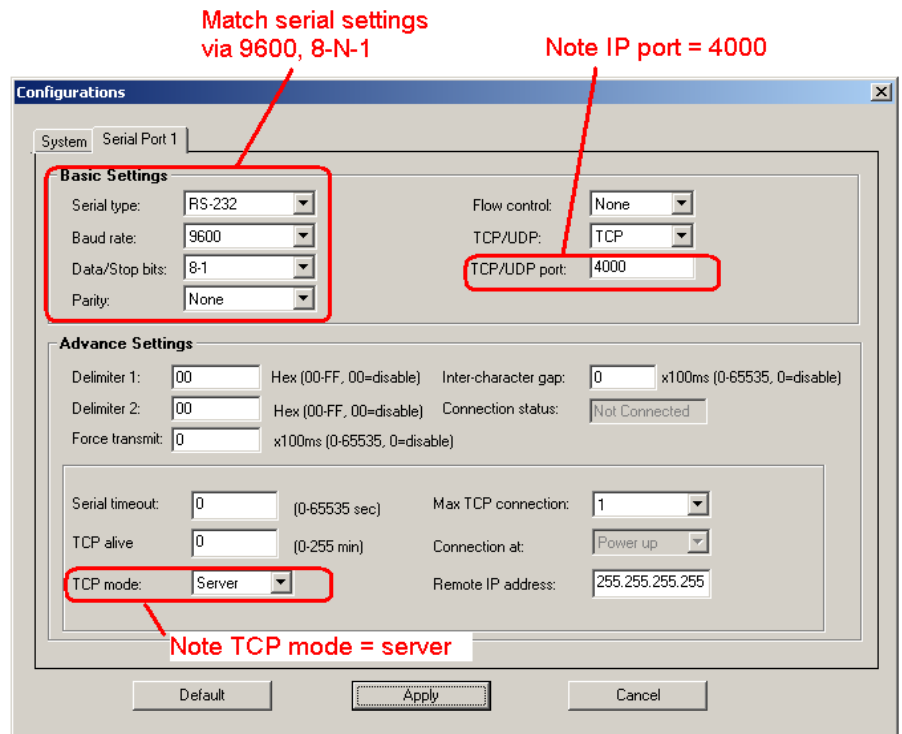

### Communication Setup:

1. Open Telnet to IP address = 192.168.0.1\* and port = 4000 **OR** use your application to communicate out the same IP address and port number.
2. Try to communicate to the end serial device connected to the Serial Server.
3. Setup is now complete (if all is successful).

\*Note that this IP address is an example only. Use the actual IP address of device.

## 12.2 VCOM Mode

User Application software  
via COM 5

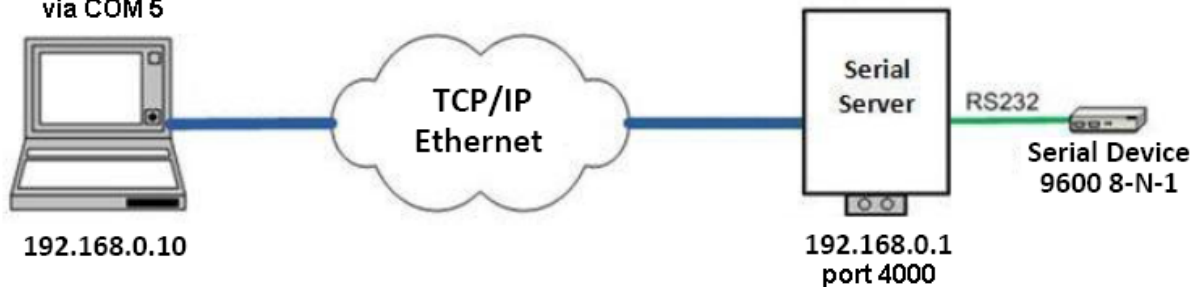

In Virtual COM mode a driver a virtual serial port is created with the PC's software. The new COM port can be named anything, and shows up in the Windows Device Manager. Since VCOM ports don't take any hardware such as expansion cards, up to 256 may be created with Vlinx Manager software.

These have all the functions of hardware serial ports, with Stop bits, Parity bits, Data bits and Baud rate all adjustable.

Windows applications use standard Windows API calls to communicate through this virtual connection with no changes to software. After connection, the LAN is transparent to the program and serial device. Applications work just as if the serial device is connected directly to a physical COM port on the PC.

Some potential applications are:

- Expand capacity of legacy industrial control PCs with limited physical serial ports.
- Allow expensive serial devices to be used by a number of users simultaneously
- Split a real COM port between a number of VCOM ports
- Allow serial port overlapping/mapping by naming a virtual port the same as a physical one.

### VCOM Configuration:

1. Connect the PC to the Serial Server using the Ethernet port and connect the serial device using a serial cable (or cross-over cable as needed).
2. Setup software and search for the Server using Vlinx Manager.

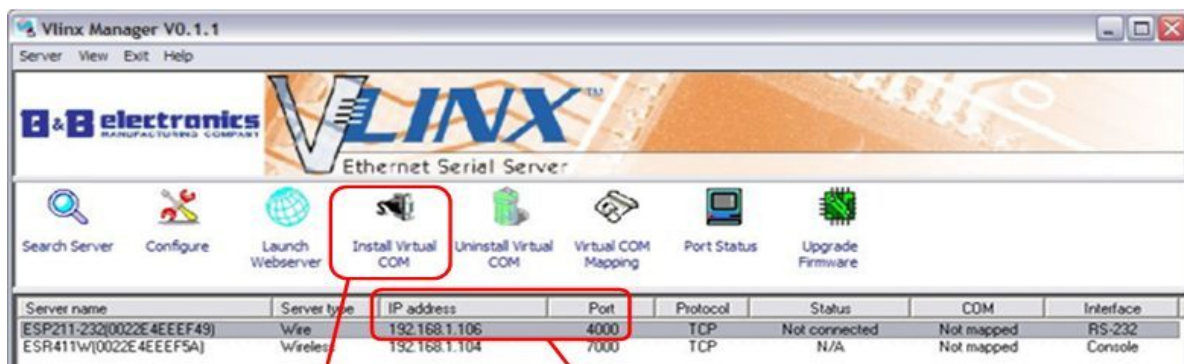

Install VCOM Port

Note IP Address = 192.168.1.106  
and Current Port = 4000

- Highlight Server unit and double click on Install VCOM.
- The software will search for an available COM number to be used. Map this to COM 5 to as in the example diagram. Choose None for “Flow Control” with “IP Address” = 192.168.0.1\* and “Port Number” = 4000.
- Verify the results of VCOM port creation by double clicking “Virtual COM Mapping” to view the new VCOM ports:

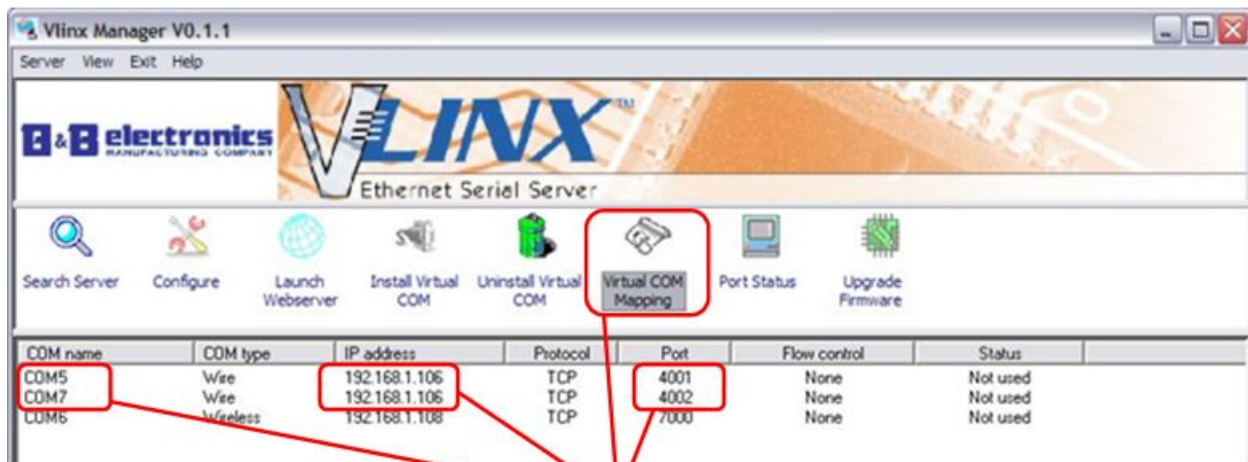
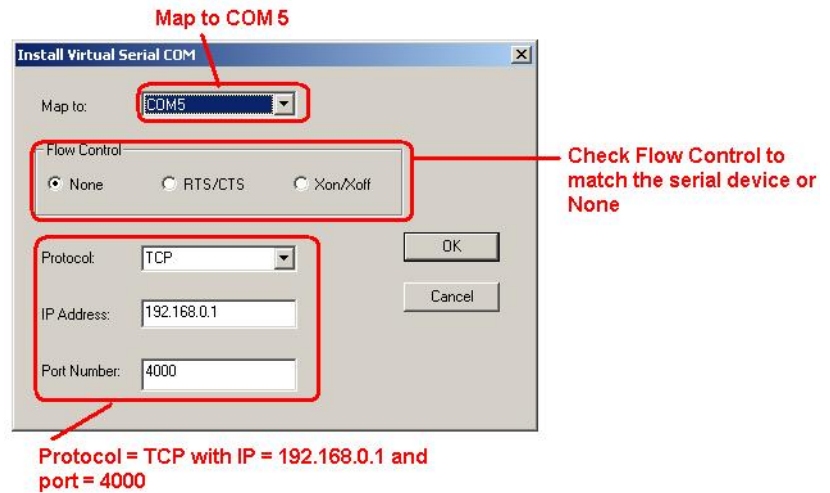

COM 5 & 7 Created @ 192.168.1.106 and Port #s 4001 & 4002

### Communication Setup:

- Open your application software and direct this to the new VCOM created (COM 5).
- Set the serial settings to match the end serial device connected on the Serial Server (9600 8-N-1). Note the unit will automatically set itself to match this serial setting of the VCOM.
- Try to communicate to the end serial device connected to the Serial Server.
- Setup is now complete (if all is successful).

\*Note that this IP address is an example only. Use the actual IP address of device.

### 12.3 Paired Mode

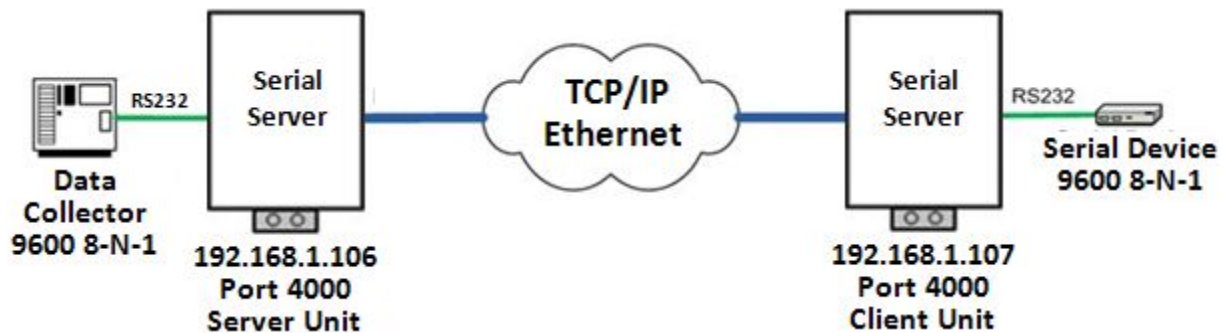

Paired Mode lets any two serial devices communicate freely using the Ethernet or LAN. Two Vlinx™ Serial Servers, one at each end, convert serial signals and handle the network-side communications automatically and invisibly as far as the serial devices are concerned.

In this mode one serial server is configured as a client and the other as a server. Each server is programmed with the mating device’s IP address. The only restriction on “cable length” is the size of the LAN or WAN.

Some benefits of paired mode are:

- Existing serial programs need no change to connect over long distances.
- No added software is needed on the host PC.
- Serial devices from the simplest to the most complex can be connected this way.
- Legacy DOS programs that use COM ports 1, 2, 3, or 4 on a computer can be used in Ethernet applications.
- What appears to the serial devices to be a direct connection is not limited by distance between the devices, or by RS-232, RS-422 and RS-485 limits.

#### GUI Configuration:

1. Connect the PC to one of the units using the Ethernet port and connect the serial device using a serial cable (or cross-over cable as needed).
2. Setup software and search for the unit using Vlinx Manager.
3. Double click on the device to open Configurations screens.
4. Note IP address of 192.168.1.106\* of the Server on the “System” page.

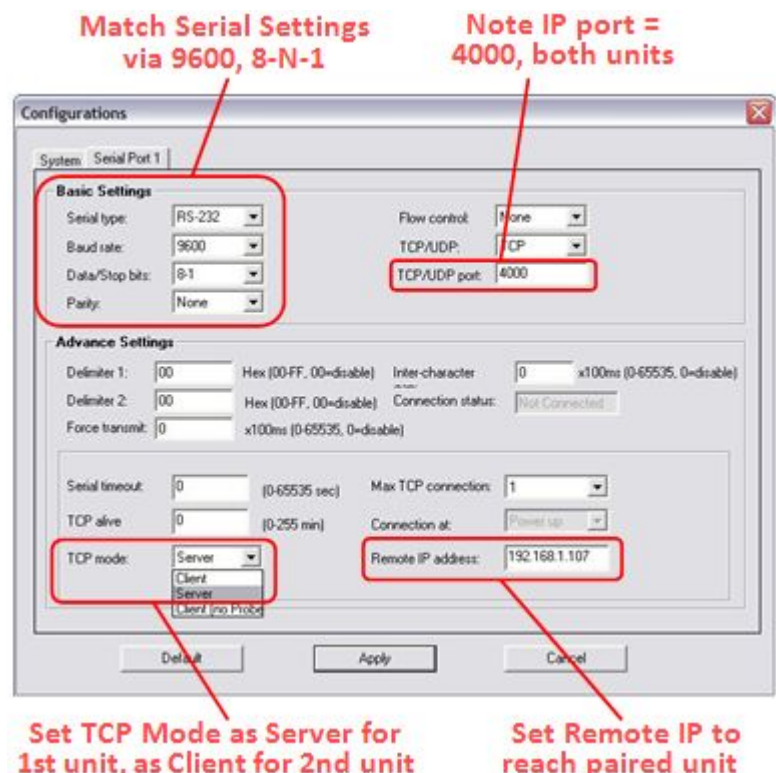

5. Click on “Serial Port 1” page and configure the unit Basic Settings to match serial device like 9600 8-N-1.
6. Note the “TCP/UDP port” = 4000.
7. Disable DHCP under Configuration> System so each unit has a stable IP address to reach the paired unit at.
8. Set the “TCP mode” of the 1<sup>st</sup> unit to Server, the 2<sup>nd</sup> unit to Client.
9. Set each server to reach the paired unit’s IP in the “Remote IP address” box.
10. Save settings and reboot.
11. Repeat steps 1 – 10 for the other server.

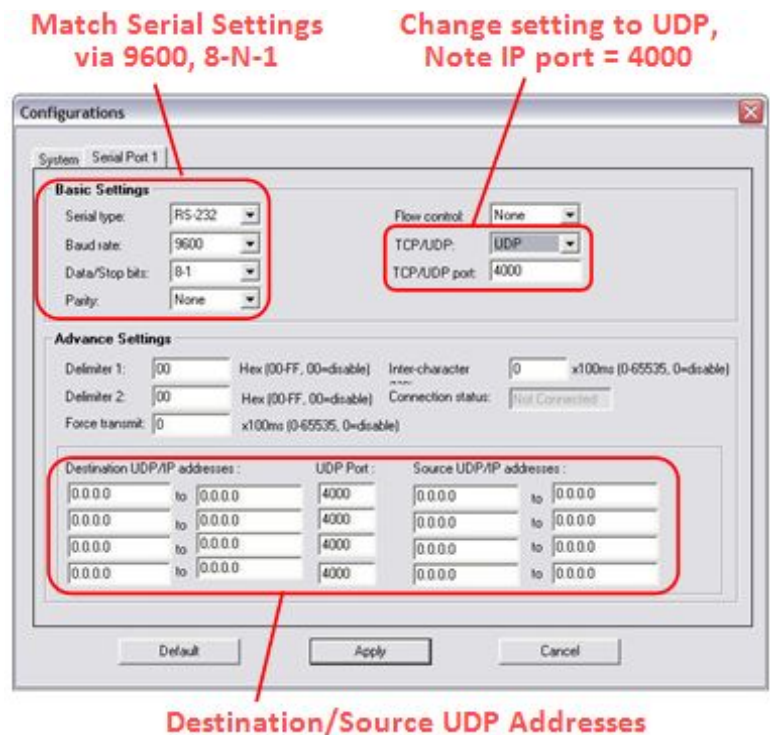

### Communication Setup:

1. Open Telnet = 192.168.1.106\* (Server) and port = 4000 **OR** use your application to communicate out the same IP address and port number.
2. Try to communicate to the end serial devices connected to each Serial Server unit.
3. Setup is now complete (if all is successful).

\*Note that this IP address is an example only. Use the actual IP address of device.

## 12.4 UDP Mode

User Application software via  
192.168.0.1 port 4000

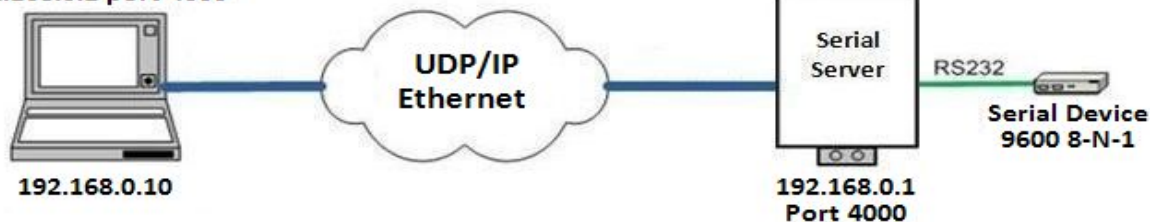

UDP/IP socket programs transmit and receive data in much the same way as TCP/IP ones, except UDP is faster. The tradeoff is that UDP doesn’t verify all data as received correctly. But for many industrial applications speed is the greater priority anyway.

If a few lost packets don’t matter, UDP is ideal. In UDP mode a serial device can broadcast or receive data from one or many host computers.

Some applications where UDP excels are:

- Message displays
- Phone systems
- Audio connections
- Graphic interfaces

### **GUI Configuration:**

1. Connect the PC to the Serial Server using the Ethernet port and connect the serial device using a serial cable (or cross-over cable as needed).
2. Setup software and search for the Server using Vlinx Manager.
3. Double click on the device to open Configurations screens.
4. Note the IP address of 192.168.0.1\* of the Server on the “System” page.
5. Click on “Serial Port 1” page and configure the unit Basic Settings to match serial device like 9600 8-N-1.
6. Enter Destination UDP addresses, keep range as small as possible to avoid flooding devices.
7. Enter Source UDP addresses.
8. Note the “TCP/UDP port” = 4000.
9. Note the “UDP mode” = server (for Direct IP mode).
10. Save settings and reboot.

### **Communication Setup:**

4. Open Telnet to IP address = 192.168.0.1\* and port = 4000 **OR** use your application to communicate out the same IP address and port number.
5. Try to communicate to the end serial device connected to the Serial Server.
6. Setup is now complete (if all is successful).

*\*Note that this IP address is an example only. Use the actual IP address of device.*

## 13. Technical Data

### 13.1 Feature List

Feature	Specification
<b>Serial Interface</b>	DB-9M connector
	Serial Port Mode: RS-232
	Baud rate (110 to 230.4Kbps, 5787bps, 165250 bps)
	Flow Control (None, RTS/CTS, Xon/Xoff)
	Data Packing Delimiters
	Forced Transmit, Inter-Character Gap
<b>LAN Interface</b>	IEEE802.3, 10/100BaseT, Auto-detect
<b>Communication Types</b>	TCP Server, TCP Client, or UDP
	Straight IP mode
	Paired Mode
	Virtual COM mode (Virtual COM drivers for Windows 2000/2003/XP/Vista)
	WinSock Lib. API
<b>Protocols</b>	TCP, UDP, IP, ARP, ICMP, HTTP, Telnet, DHCP
	UDP Multicast
<b>Protocols Relative Function</b>	Client requests connection at Power up or Data arrival
	TCP Inactivity Timeout (TCP keep-alive timeout)
	Serial Inactivity Timeout
	Up to 8 TCP Client Connections
	TCP Probe function
	Port Status Monitoring
<b>Management</b>	Console, Telnet, Web pages
	Remote Administrator
	Firmware upgrade
	Import/Export Configurations file
<b>Security</b>	Password Access
	IP Address Filtering
<b>Power &amp; Environment</b>	DC Input: 12VDC
	Operating Temperature: 0 to 55 °C
<b>Certifications</b>	CE, FCC
<b>Mechanical</b>	Rugged IP30 Metal Case
	DIN rail mount, Panel mount, or Desktop
	Dimensions(mm): 52 x 79 x 22

## 13.2 Default Settings

The Vlinx Serial Server Default Settings are as follows:

<b>Model Name:</b>	ESP211-232
<b>Server Name:</b>	ESP211-232 (MAC Address of the Unit)
<b>Serial Number:</b>	xxxxxxxxxxxxxxxx(printed on bottom of unit)
<b>Password:</b>	(No Password)
<b>DHCP:</b>	Enable
<b>IP Address:</b>	192.168.0.1 (if DHCP not available)
<b>Net Mask:</b>	255.255.255.0
<b>Gateway:</b>	192.168.0.254
<b>MAC Address:</b>	xx:xx:xx:xx(printed on bottom of the unit)
<b>FW Version:</b>	Current Firmware Vx.x.x
<b>Baud Rate:</b>	9600
<b>Data/Stop bits:</b>	8-1
<b>Parity:</b>	None
<b>Flow Control:</b>	None
<b>TCP/UDP Protocol:</b>	TCP
<b>Serial timeout:</b>	0 second
<b>TCP alive timeout:</b>	0 minute
<b>TCP Mode:</b>	Server
<b>Delimiter Hex 1:</b>	00
<b>Delimiter Hex 2:</b>	00
<b>Force Transmit:</b>	0 ms
<b>Inter-character Gap:</b>	0 ms
<b>TCP/UDP port:</b>	4000
<b>Serial Type:</b>	RS-232
<b>Max connection:</b>	1
<b>Remote IP Address:</b>	255.255.255.255

## Appendix A: Well-Known TCP/UDP Port Numbers

Port numbers are divided into three ranges: Well Known Ports, Registered Ports, and Dynamic and/or Private Ports. Well Known Ports are those from 0 through 1023. Registered Ports are those from 1024 through 49151. Dynamic and/or Private Ports are those from 49152 through 65535.

Well Known Ports are assigned by IANA, and on most systems, can only be used by system processes or by programs executed by privileged users. Table below shows some of the well-known port numbers. For more details, please visit the IANA website: <http://www.iana.org/assignments/port-numbers>

Port Number	Protocol	TCP/UDP
21	FTP (File Transfer Protocol)	TCP
22	SSH (Secure Shell)	TCP
23	Telnet	TCP
25	SMTP (Simple Mail Transfer Protocol)	TCP
37	Time	TCP, UCP
39	RLP (Resource Location Protocol)	UDP
49	TACACS, TACACS+	UDP
53	DNS	UDP
67	BOOTP server	UDP
68	BOOTP client	UDP
69	TFTP	UDP
70	Gopher	TCP
79	Finger	TCP
80	HTTP	TCP
110	POP3	TCP
119	NNTP (Network News Transfer Protocol)	TCP
161/162	SNMP	UDP
443	HTTPS	TCP

**Notice!!!** Please reserve the following port numbers for the Vlinx Serial Server operation – **6400** (TCP Probe / CMD), **6666** (UDP Search All), **6669** (UDP CMD), **6690** (UDP Search Specific).

Your attached firewall device must not block the reserved port numbers mentioned above, or the port numbers specified in **TCP/UDP port** in **Configurations** window.

## Appendix B: Serial Port Pin-outs

### DB-9 Pin-outs in RS-232 Mode

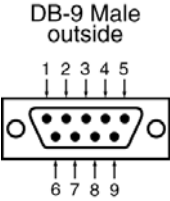
			
RS-232 Signal Name	Direction	RS-232	DB-9M Pin
Carrier Detect	In	DCD	1
Receive Data	In	RXD	2
Transmit Data	Out	TXD	3
Data Terminal Ready	Out	DTR	4
Signal Ground	---	GND	5
Data Set Ready	In	DSR	6
Request To Send	Out	RTS	7
Clear To Send	In	CTS	8
Ring Indicator	In	RI	9

**Figure 42 DB-9 Pin-outs in RS-232 Mode**

## Appendix C: Ethernet Cable Pin-outs

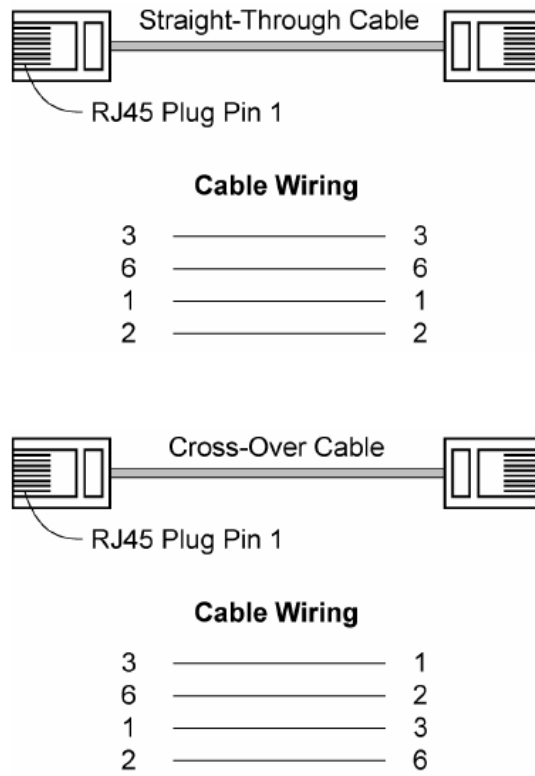

Figure 43 Ethernet Cable Pin-outs

## Appendix D: Regulation Information

### Regulation Information

#### FCC

This equipment has been tested and found to comply with the limits for a Class A digital device, pursuant to Part 15 of the FCC Rules. These limits are designed to provide reasonable protection against harmful interference in a commercial installation. This equipment generates, uses, and can radiate radio frequency energy and if not installed and used in accordance with the instructions, may cause harmful interference to radio communications. Operation of this equipment in a residential environment may cause harmful interference.

#### CE

This equipment has been tested and found to comply with the CE regulations of Class A.

#### RoHS

All contents of this package, including products, packing materials and documentation comply with RoHS.

