

# MESR9xx

## Vlinx™ Industrial MODBUS Ethernet to Serial Gateway

PRODUCT INFORMATION

- ✓ Ethernet Enable MODBUS RS-232/422/485
- ✓ MODBUS TCP, ASCII & RTU
- ✓ Modbus Flexibility – Serial & Ethernet, Masters & Slaves
- ✓ Modbus Messaging Priority Control
- ✓ View Messaging Status in Real Time
- ✓ Complete Ethernet Fiber Options
- ✓ Easy Configuration Software



MESR MODBUS Gateways bridge devices on MODBUS serial networks (RS-232, RS-422 or RS-485) with those on MODBUS TCP networks, allowing seamless integration. The serial ports can be accessed over a LAN or WAN using Direct IP Mode connections. Supporting up to 16 masters and 32 slaves, the gateways feature autodetecting 10/100 copper and fiber optic options. The easy to use software is designed for Windows 2000, 2003 Server, XP and Vista and features Modbus messaging priority control and allows management through multiple TCP/IP client sessions. Serial data rates up to 230 kbps ensure maximum network flexibility. MESR9xx gateways are built for use in industrial environments, featuring a slim IP30 DIN rail mountable case. They operate from a range of DC power supply voltages and have pluggable terminal block connectors. An external power supply, sold separately, is required. The photograph above is an MESR922T gateway. The MESR92x units have an additional Ethernet port which functions much like an Ethernet Switch, allowing pass-through connectivity for other Ethernet devices. This port can also be used to “daisy chain” multiple gateways. MESR90x units have one Ethernet port. B&B Electronics’ Vlinx™ is your number one choice for Ethernet to Serial conversion.

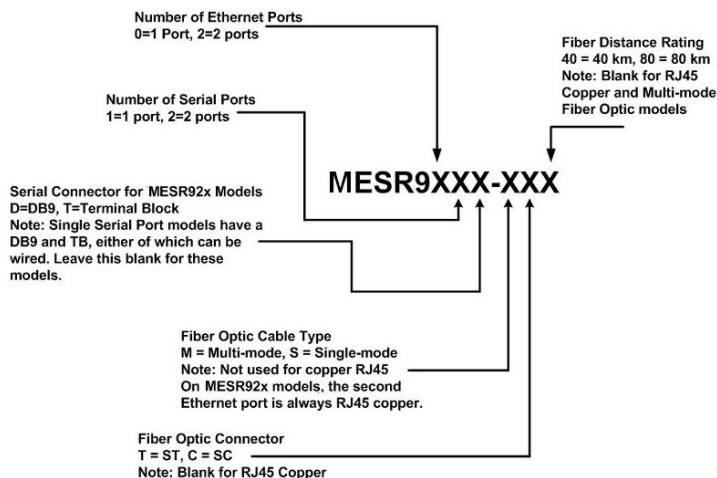

### Ordering Information

Vlinx Modbus Serial Server See Chart Above

### Accessory Items

MDR-40-24	DIN Rail Power Supply, 24VDC, 1.7A
DRPM25	Panel Mount Adapter

B&B ELECTRONICS

## Specifications

### Serial Technology

RS-232	TD, RD, RTS, CTS, DTR, DSR, DTD, GND
RS-485 2-Wire	Data A(-), Data B(+), GND
RS-422/485 4-Wire	TDA(-), TDB(+), RDA(-), RDB(+), GND
Serial Connector	DB9M or Removable Terminal Blocks 12 to 28 AWG
Data Rate	Up to 230.4 Kbps

### Fiber Optic Technology

#### MESR9xx-Mx

Type / Wavelength	Multi-mode / 1310 nm
Output Power	(-)19 to (-) 14 dBm
Receive Sensitivity	~ (-) 32 dBm
Cable	62.5 / 125 µm
Connector	SC or ST
Range	1.2 miles (2 km)

#### MESR9xx-Sx

Type / Wavelength	Single-mode / 1310 nm
Output Power	(-) 15 to (-) 8 dBm
Receive Sensitivity	~ (-) 32 dBm
Cable	9 / 125 µm
Connector	SC or ST
Range	9.3 miles (15 km)

#### MESR9xx-Sx40

Type / Wavelength	Single-mode / 1310 nm
Output Power	(-) 5 to 0 dBm
Receive Sensitivity	~ (-) 34 dBm
Cable	9 / 125 µm
Connector	SC or ST
Range	25 miles (40 km)

#### MESR9xx-Sx80

Type / Wavelength	Single-mode / 1510 nm
Output Power	(-) 5 to 0 dBm
Receive Sensitivity	~ (-) 34 dBm
Cable	9 / 125 µm
Connector	SC or ST
Range	49.7 miles (80 km)

### Power

Source	External
Input Voltage	10 to 48 VDC
Connector	Removable Terminal Block (12 – 28 AWG)

### Power Consumption

MESR90x	4.0 Watts
MESR92x	6.0 Watts

### Mechanical

LED Indicators	Serial Port, Ethernet Link, Ready
Switches	Reset Button
Dimensions	MESR90x-1.2x3.2x4.7in (3.0x8.1x11.9cm) MESR92x-1.2x4.0x5.9in (3.0x10.2x15.0cm)
Enclosure	35mm DIN mount, Plastic, IP 30
Weight	MESR90x – 0.33 lbs (149.7 g) MESR92x – 0.45 lbs (204.1 g)
CAD Drawing	Available on website

### Environmental

Operating Temp	- 29 to 158 °F (- 34 to 70 °C)
Storage Temp	- 40 to 176° F (-40 to 80° C)
Operating Humidity	0 to 95% Non-condensing
MTBF MESR90x	~ 132309 Hours
MTBF MESR92x	~ 102593 Hours
MTBF Calc Method	Parts Count Reliability Prediction

### Network

Serial Memory	8 KB per port
Network Memory	4 KB
IP Port Addresses	5300 – Heartbeat and configuration Setting in TCP Mode (paired mode) 8888 – MESR 9xx Update

### Network Communications

LAN	10/100 Mbps Auto-detecting
<b>Network Physical Layer Standards</b>	
Ethernet	IEEE 802.3 auto detecting & auto MDI/MDX 10/100

### Protocols

TCP, IPv4, ARP, Telnet, HTTP 1.0, ICMP/PING, DHCP/BOOTP	
IP Mode	Static, DHCP
TCP	User definable

### Other

Mode	MODBUS RTU Master / Slave MODBUS ASCII Master/Slave
Search	Serial direct COM and Ethernet Auto search or specific IP
Diagnostics	Display PC IP, ping, save test config. (text readable)
Firmware Upgrade	Web GUI through Ethernet

### Software

Vlix Manager	Supports Windows 2000, 2003 Server, XP, and Vista
--------------	--

### Ethernet Pass-through Port (MESR92x)

Standards	IEEE 802.3, 802.3u, 802.3x
Processing Type	Store and Forward with 802.3x full duplex, non blocking flow control
Flow Control	IEEE 802.3x flow control, back pressure flow control
MAC Address Table	2K

### Configuration Software

OS Compatibility	Windows 2000, 2003 Server XP, Vista
------------------	--

### Regulatory

Compliance	FCC, CE
------------	---------

## Application Examples

### Ethernet Master Serial Slaves

MESR9xx modules can be used to integrate serial slave devices on a MODBUS TCP network. This allows TCP Masters to control serial slave devices.

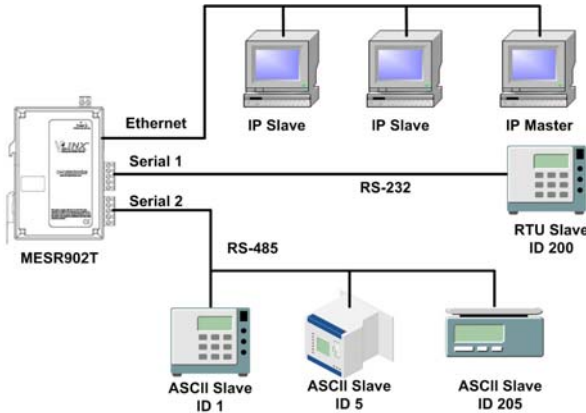

### Serial & Ethernet Masters, Serial & Ethernet Slaves

MESR9xx modules can also integrate multiple master devices onto serial and Ethernet networks.

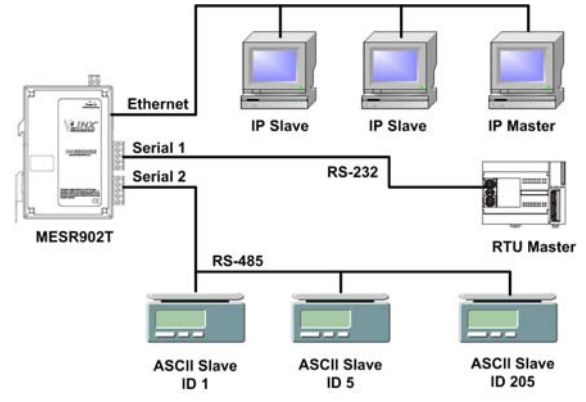

### Two Identical Hard Coded Slaves

In this scenario, two slave devices that are hard coded with the same ID are required. This is accomplished by placing them on different serial ports.

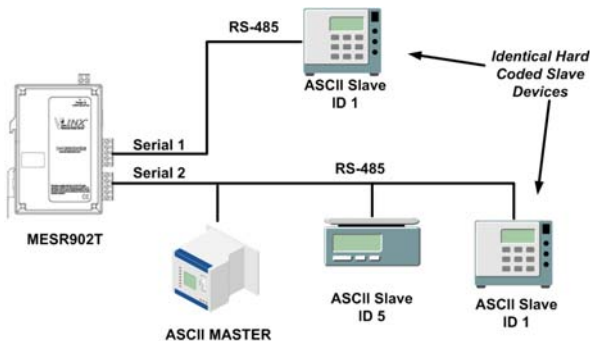

### Serial Masters with IP Slaves

Serial Masters can be used to control IP slaves.

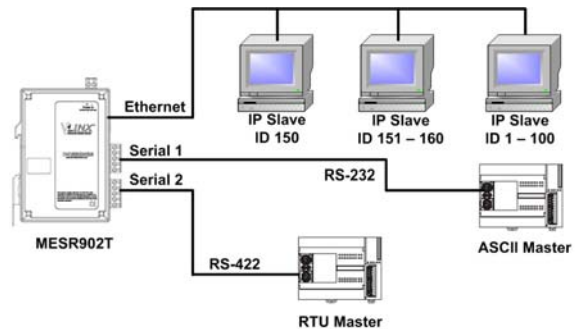

### Identical Networks

In this scenario, identical or backup production lines can be controlled by the same IP Master. This allows the duplicate networks to be configured identically, saving documentation and maintenance time.

