

# RS-232 Port Combiner

## Model 232PTC

### Introduction

B&B Electronics' Model 232PTC permits two or more serial devices to share a serial port on a host computer. When one of the devices on either of the slave ports transmits data, it captures the data path to the master port and locks out the other slave port. When data transmission is finished, either slave port gets access to the master port by being the first to start sending data. The RTS line can also be used to control data flow to the master port. The 232PTC can be cascaded to combine as many devices as needed into one host port. A typical application would be to share one host port with several terminals, scanners, scales, or other devices that only need access to the host port occasionally as shown in Figure 1.

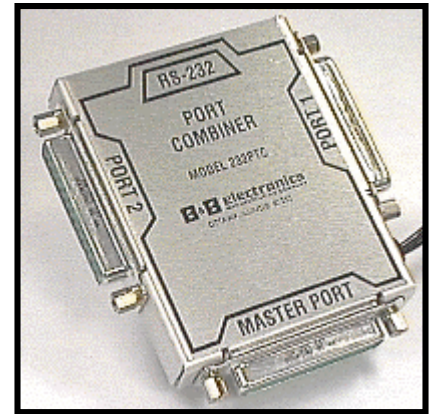

### Operation

#### Data flow from master port to slave ports

All data that is sent to the TX line, pin 2 on the master port, is broadcast to both slave ports under all conditions. This data appears on pin 3 of each slave port.

#### Data flow from slave ports to master port

Data that is sent to the TX line (pin 2) on the slave ports must compete for the path to the master port. There are two methods of capturing the path to the master port, RTS and automatic data sensing. The first slave port to either raise its RTS line or transmit data captures the path to the master port. The path will be locked on that slave port until it either lowers its RTS line, or 50 milliseconds after the end of its transmission. Note that the 232PTC does not buffer any data, any data sent to the opposite slave port during this period will be lost. The 50ms timeout period can be modified, contact B&B's technical support for further information.

#### Handshake Signals

The CTS signal on each slave port indicates to the slave devices if the path to the master port is available. If the slave port's CTS line is high, data received by that port will be transmitted out the master port. If CTS is low, the opposite slave port has captured the path to the master and any data at the inactive slave port will be lost. For example, if both slave ports are inactive and have RTS low, CTS will be high at both slave ports, indicating that the path is available. As soon as one slave port captures the path by either beginning its transmission or raising its RTS line, the CTS signal at the opposite slave port will drop to the low state.

The RTS output on the pin 4 of the master port follows the RTS signal level found on the active slave port.

#### Pinouts

All ports on the 232PTC are configured as RS-232 DCE ports, using DB25 female connectors. Note that a null-modem type connection will be required to connect the 232PTC to other DCE configured ports. Tables 1 and 2 and Figure 1 show the configuration of each port.

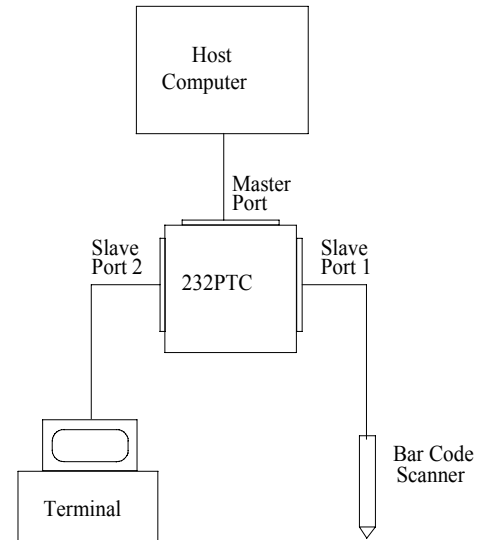

**Figure 1: Application Example**

**Table 1  
Master Port Pinouts**

Signal	Pin	Direction
TD	2	Input
RD	3	Output
RTS	4	Output
GND	7	-----
12VDC	9	-----

**Table 2  
Slave Port Pinouts**

Signal	Pin	Direction
TD	2	Input
RD	3	Output
RTS	4	Input
CTS	5	Output
GND	7	-----
12VDC	9	-----
5VDC	16	-----

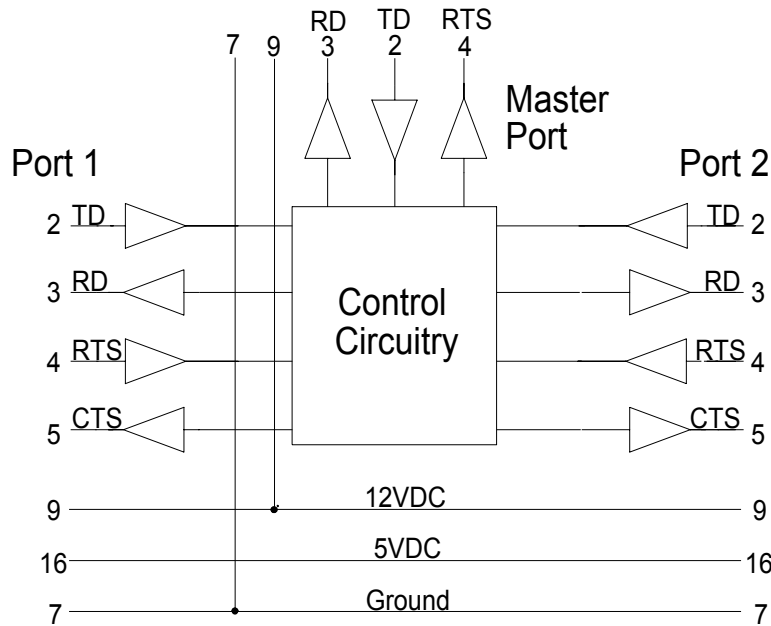

**232PTC Port Diagram**

In addition to the standard RS-232 signals, DC power is available for use by low power devices connected to the 232PTC. The unregulated 12VDC power is brought out on pin 9 of all three connectors. In addition, a regulated 5VDC is brought out on pin 16 of the two slave ports. A total of 225mA may be drawn from the 5V supply. A total of 325mA may be drawn from the 12V supply. The total current drawn from the unit must be less than 325mA.

**Important:** Do not connect to pin 9 or 16 in your RS-232 cables if the power is not being used.

**Cascading Port Combiners**

Port combiners can be cascaded by connecting the master port of each successive unit to one of the slave ports of the preceding unit. Each additional port combiner adds one slave port to the system.

**Specifications**

- Dimensions: 3.01" x 3.40" x 0.58" (76.45mm x 86.36mm x 14.74mm)
- Connectors: (3) DB-25 female, RS-232 DCE configuration
- Power Supply: 12VDC 500mA wall transformer (included)
- Current Draw: 175mA
- 5VDC Outputs: Slave ports pin 16, 225mA max. total output
- 12VDC Outputs: Unregulated, all ports pin 9, 325mA max. total output
- Operating Temp: 0-50 °C
- Signals: TD, RD, RTS (slave to master only)  
CTS indicates open channel (slave only)

DECLARATION OF CONFORMITY	
Manufacturer's Name:	B&B Electronics Manufacturing Company
Manufacturer's Address:	P.O. Box 1040 707 Dayton Road Ottawa, IL 61350 USA
Model Numbers:	232PTC
Description:	RS-232 Two Port Combiner
Type:	Light industrial ITE equipment
Application of Council Directive:	89/336/EEC
Standards:	EN 50082-1:1998 EN 50082-1 IEC 801(-3, -4) EN 61000-4 (-2, -3, -4, -6)
 Michael J. Fahrion, Director of Engineering	
