



Multi-Interface PCI Bus Serial Cards

(RS-232 / RS-422 / RS-485)

Models 3PCIU2, 3PCIU4, 3PCIU8

(Non-Isolated)

and

Models 3PCIOU1, 3PCIOU2, 3PCIOU4

(Isolated)



B & B electronics
MANUFACTURING COMPANY

Manual Documentation Number 3PCIoUx-1008



International Headquarters

B&B Electronics Mfg. Co. Inc.
707 Dayton Road
Ottawa, IL 61350 USA

Phone (815) 433-5100 -- **General Fax** (815) 433-5105

Website: www.bb-elec.com

Sales e-mail: orders@bb-elec.com -- **Fax** (815) 433-5109

Technical Support e-mail: support@bb.elec.com -- **Fax** (815) 433-5104

European Headquarters

B&B Electronics
Westlink Commercial Park
Oranmore, Co. Galway, Ireland

Phone +353 91-792444 -- **Fax** +353 91-792445

Website: www.bb-europe.com

Sales e-mail: sales@bb-europe.com

Technical Support e-mail: support@bb-europe.com

© 2008 B&B Electronics – Revised February 2008

Manual Documentation Number 3PCIoUx-1008

B&B Electronics Mfg Co Inc – 707 Dayton Rd - PO Box 1040 - Ottawa IL 61350 - Ph 815-433-5100 - Fax 815-433-5104 – www.bb-elec.com
B&B Electronics Ltd – Westlink Commercial Park – Oranmore, Galway, Ireland – Ph +353 91-792444 – Fax +353 91-792445 – www.bb-europe.com



CAUTION:

This is an Electrostatic Sensitive Device. Use ESD precautions for safe handling.

Before removing the card from the anti-static protective packaging:

- Discharge any static electricity buildup on your body by touching a large grounded metal surface or the metal chassis on equipment connected to earth ground by a 3-wire power cord. Use of a grounding wrist strap is recommended.*
- Avoid touching the gold connectors or other parts on the card except when necessary to set the configuration DIP switches.*
- Remove AC power from the computer before inserting the card*

© 2008 B&B Electronics. No part of this publication may be reproduced or transmitted in any form or by any means, electronic or mechanical, including photography, recording, or any information storage and retrieval system without written consent. Information in this manual is subject to change without notice, and does not represent a commitment on the part of B&B Electronics.

B&B Electronics shall not be liable for incidental or consequential damages resulting from the furnishing, performance, or use of this manual.

All brand names used in this manual are the registered trademarks of their respective owners. The use of trademarks or other designations in this publication is for reference purposes only and does not constitute an endorsement by the trademark holder.

Table of Contents

TABLE OF CONTENTS	II
CHAPTER 1: GENERAL INFORMATION	1
INTRODUCTION	1
FEATURES.....	1
MIPORT MODELS AND FEATURES.....	3
QUICK START GUIDE	5
SPECIFICATIONS.....	7
CHAPTER 2: SERIAL CARD SETUP.....	8
PRE-SETUP STEPS	8
<i>ESD Precautions</i>	8
<i>Initial Configuration</i>	8
OVERVIEW OF OPERATIONAL MODES.....	9
<i>RS-232 Mode</i>	9
<i>RS-422 Mode</i>	9
<i>RS-485 Mode</i>	9
OPERATING MODE SELECTION	10
<i>Setting the DIP Switches on RS-232/422/485 Ports</i>	11
<i>Setting the DIP Switches on RS-422/485 Only Ports</i>	12
INSTALLING THE SERIAL CARD.....	14
CHAPTER 3: DRIVER SOFTWARE INSTALLATION.....	15
INSTALLING WINDOWS VISTA DRIVER SOFTWARE.....	15
<i>Pre-Installation Steps</i>	15
<i>Using the Found New Hardware Wizard</i>	16
INSTALLING WINDOWS XP PROFESSIONAL DRIVER SOFTWARE	17
<i>Windows Settings</i>	17
<i>Pre-Installation Steps</i>	17
<i>Using the Found New Hardware Wizard</i>	18
<i>Checking the Driver Installation</i>	20
INSTALLING WINDOWS 2000 PROFESSIONAL DRIVER SOFTWARE	22
<i>Windows Settings</i>	22
<i>Pre-Installation Steps</i>	22
<i>Using the Found New Hardware Wizard</i>	23
<i>Checking the Driver Installation</i>	27
INSTALLING WINDOWS 98 OR ME DRIVER SOFTWARE.....	28
<i>Windows Settings</i>	28
<i>Pre-Installation Steps</i>	28
<i>Using the Add New Hardware Wizard</i>	29
<i>Checking the Driver Installation</i>	32

INSTALLING WINDOWS NT DRIVER SOFTWARE	34
INSTALLING WINDOWS NT DRIVER SOFTWARE	34
<i>Windows Settings</i>	34
<i>Pre-Installation Steps</i>	34
<i>Installing the Driver Software</i>	34
<i>Configuring the Serial Ports</i>	37
CHAPTER 4: SETTING DRIVER OPTIONS	40
CONFIGURING PORT SETTINGS (DOES NOT APPLY TO WINDOWS NT.)	40
SETTING THE FIFO BUFFERS	41
SETTING THE RTS CONTROL PARAMETER	42
SETTING THE HARDWARE HANDSHAKING LEVEL	42
CHANGING THE COM PORT NAME/NUMBER.....	42
CHAPTER 5: INSTALLING LINUX DRIVER SOFTWARE	44
INSTALLING MIPORT DRIVERS IN LINUX	44
<i>Preparing the Linux Files</i>	44
<i>Compiling the Driver</i>	44
<i>Installing the Driver</i>	45
CHECKING THE DRIVER INSTALLATION	47
USING THE EXAR SERIAL GUI EXAMPLE APPLICATION	48
<i>Preparing the Example Application Files</i>	48
<i>Running the Exar Serial Test GUI</i>	48
<i>Configuring Port Settings</i>	50
CHAPTER 6: REMOVING DRIVERS, PORTS AND CARDS.....	51
REMOVING MIPORT CARDS FROM WIN98/ME/2000/2003 SERVER/XP/VISTA.....	51
<i>Uninstalling the MIport Card</i>	51
<i>Uninstalling the COM ports</i>	51
<i>Removing INF and PNF Driver Files</i>	52
REMOVING MIPORT CARDS FROM WINDOWS NT	54
<i>Uninstalling the MIport Card</i>	54
<i>Uninstalling the Driver</i>	54
CHAPTER 7: RS-232 CONNECTIONS/OPERATION.....	55
RS-232 MODE	55
RS-232 SIGNAL DESIGNATIONS AND DB-9 PINOUT	55
<i>RS-232 Signal Designations</i>	56
DTE AND DCE	56
RS-232 SIGNAL LEVELS	57
HANDSHAKING	57
RTS CONTROL IN RS-232 MODE	57
CHAPTER 8: RS-422/485 CONNECTIONS/OPERATION	59
RS-422/485 MODE	59

RS-422/485 SIGNAL DESIGNATIONS AND DB-9 PINOUT	59
<i>RS-422/485 Signal Designations</i>	60
RS-422/485 DIFFERENTIAL SIGNALS	60
RS-422 OPERATION	61
<i>RS-422 Limitations</i>	61
RS-485 OPERATION	61
<i>Send Data Control</i>	62
RS-485 TERMINATION RESISTORS	63
RS-485 NETWORK BIASING	63
2-WIRE RS-485 CONNECTIONS	65
<i>2-Wire RS-485 Mode</i>	65
4-WIRE RS-422 AND RS-485 CONNECTIONS	65
<i>RS-422 Point to Point Connection</i>	65
<i>RS-422 Point to Multipoints Connection</i>	66
<i>4-Wire RS-485 Connection</i>	66
CHAPTER 9: TROUBLESHOOTING MIPOINT CARDS.....	68
STARTING UP	68
CHECKING CONNECTIONS	68
<i>RS-232/422/485 Operation</i>	68
<i>RS-232 Operation</i>	68
<i>RS-422/485 Operation</i>	69
CHECKING THE MIPOINT CARD	69
<i>Support</i>	71
APPENDIX A: DIP SWITCH/MODE SETTINGS	1
SETTING THE DIP SWITCHES ON RS-232/422/485 PORTS	1
<i>DIP Switch 1 (RS-232/422/485 ports)</i>	1
<i>DIP Switch 2 (RS-232/422/485 ports)</i>	1
<i>DIP Switch 3 (RS-232/422/485 ports)</i>	2
SETTING THE DIP SWITCHES ON RS-422/485 ONLY PORTS	2
APPENDIX B: CONNECTOR PINOUTS	1
RS-232 PINOUTS	1
RS-422/485 PINOUTS	2
APPENDIX C: TROUBLESHOOTING WITH COMTEST	1
COMTEST FEATURES	1
INSTALLING COMTEST	2
LOOPBACK TESTING WITH COMTEST	2
APPENDIX D: DECLARATION OF CONFORMITY STATEMENT	5

Chapter 1: General Information

Introduction

MIport PCI serial interface cards allow you to add RS-232, RS-422 and RS-485 interfaces to Windows based computers equipped with a PCI bus. Depending on your choice of card one, two or four optically isolated serial ports, or two, four or eight non-isolated serial ports, can be added. MIport PCI serial cards are Plug and Play compatible, which allows the Windows Operating System and driver to set the addresses and IRQ used by the card.



Figure 1. A 3PCI0U2 Optically Isolated Two-Port PCI Serial Interface Card

Features

- Optically isolated or non-isolated models available
- Isolated models available in 1, 2 or 4 ports
- Non-isolated models available in 2, 4 or 8 ports
- 4 and 8 port models include fanout cables
- Plug & Play compatible – Windows sets addresses and IRQ used
- 5 volt and 3.3 volt PCI bus compatible
- PCI-X compatible

- Conform to the PCI V2.3 Universal PCI specification
- RS-232/RS-422/RS-485 interfaces
- 2-wire or 4-wire RS-485 operation (half or full-duplex)
- Automatic Send Data Control for RS-485 operation
- Buffered high speed XR17D15x PCI Bus UARTs (16C550 compatible) with 64 byte FIFOs for input/output with programmable trigger thresholds
- Advanced driver function for COM port rename (Refer to Chapter 4)
- Supports baud rates up to 460.8 kbps
- Windows 98, ME, NT4.0, 2000, 2003 Server, XP, Vista and Linux 2.4 supported

MIport Models and Features



Model Number	Ports	Interface	Connectors
3PCIOU1	1	RS-232/422/485	DB-9 male
			
3PCIOU2	2	RS-232/422/485	DB-9 male
			
3PCIOU4	4	2 RS-232/422/485 ports 2 RS-422/485 ports	2 x DB-9 male 2 x DB-9 male use 2 nd expansion slot
			

Figure 2. MIport Optically Isolated PCI Cards



Model Number	Ports	Interface	Connectors
3PCIU2	2	RS-232/422/485	2 x DB-9 male
			
3PCIU4	4	RS-232/422/485	DB-37 female (plus DB-37 to 4x DB-9 male cable)
			
3PCIU8	8	4 RS-232/422/485 ports 4 RS-232 ports	DB-78 female (plus DB-78 to 8x DB-9 male cable)
			

Figure 3. Mlport Non-Isolated PCI Cards

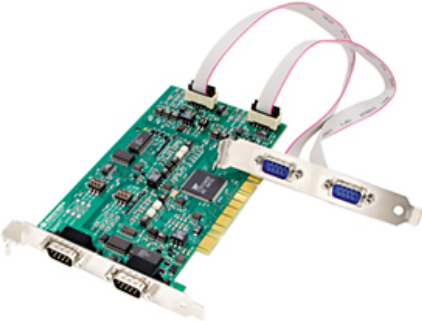
Quick Start Guide

CAUTION:

This is an Electrostatic Sensitive Device. Use ESD precautions for safe handling.

Before removing the card from the anti-static protective packaging:

- *Discharge any static electricity buildup on your body by touching a large grounded metal surface or the metal chassis on equipment connected to earth ground by a 3-wire power cord. Use of a grounding wrist strap is recommended.*
- *Avoid touching the gold connectors or other parts on the card except when necessary to set the configuration DIP switches.*
- *Remove AC power from the computer before inserting the card*

1. Determine the interface requirements of your application, including:
 - a. Interface standard(s) (RS-232, RS-422 or RS-485)
 - b. Data transmission mode (Two-wire or four-wire)
 - c. Cable lengths, connectors, pinouts

Note: For information on cables and pinouts refer to Chapter 5 (RS-232) or Chapter 6 (RS-422/RS-485).

2. Set the operating mode DIP switches to configure the communications interface for the required interface standard and transmit/receive mode.

Note: Refer to the DIP switch table in Chapter 2.

3. Shut down your computer. (You may want to unplug the computer power cord to prevent accidentally turning the computer on during installation.)
4. Install the PCI card in your computer and replace the cover.
5. Connect the cable(s) from the card to your peripheral device (Cable also can be connected/changed later.)
6. Power up the computer
7. Insert the driver disc into your CD-ROM drive
8. Wait until new hardware is detected.
9. Follow the instructions in the Add New Hardware Wizard. (This varies depending on your operating system.)

Note: Refer to Chapter 3.

10. Check for new COM ports in Device Manager.

11. Select the appropriate COM port, double-click and check properties.
12. Check and set up Port Settings
13. Under Advanced Settings, set Buffer, RTS Control and Hysteresis Level. Change the COM port name, if necessary.
14. If your card was not connected to a peripheral device in Step 5, make your connections now. (Powering down the computer while making connections is recommended.)
15. Use a communications test program (such as ComTest) to check communications between the computer and your peripheral device.

Specifications

OS Supported	Windows 98, ME, NT 4.0, 2000, 2003 Server, XP, Vista and Linux 2.4
Bus Slot	PCI bus (33MHz/32-bit) PCI Bus specification Requires one PCI slot (3.3V or 5V signaling)
Baud Rates	Maximum: Up to 460.8 kbps (RS-232/422/485) Typical: 75, 110, 134, 150, 300, 600, 1200, 1800, 2400, 4800, 7200, 9600, 14.4k, 19.2k, 38.4k, 57.6k, 115.2k, 230.4k, 460.8k
UARTs	XR17D15x (16C550 compatible) with 64 byte FIFO buffers
Character Length	5, 6, 7 or 8 bits
Parity	Even, odd, none, space or mark
Stop Bits	1, 1.5 or 2
Optical Isolation (3PCIOU1, 3PCIOU2, 3PCIOU4 only)	2000 VDC minimum on all lines Ports are isolated from the PC power and ground, as well as other ports on the same card.
Connectors	3PCIOU1: 1 – DB-9 male 3PCIOU2: 2 – DB-9 male 3PCIOU4: 2 – DB-9 male (RS-232/422/485 ports) 2 – DB-9 male via ribbon cable on 2 nd expansion slot bracket (RS-422/485 ports) 3PCIU2: 2 – DB-9 male 3PCIU4: 1 – DB-37 female with DB-37 to 4 x DB-9 male cable 3PCIU8: 1 - DB-78 female with DB-78 to 8 x DB-9 male cable (4 x RS-232/422/485 and 4 x RS-232)
Data Signals	RS-232: TD, RD, RTS, CTS, DTR, DSR, DCD, RI and GND (TD, RD, RTS, CTS, GND only on 3PCIOU4) RS-422: TD(A)-, TD(B)+, RD(A)-, RD(B)+ and GND RS-485: Data(A)-, Data(B)+ and GND
Environmental	Operating temperature range: 0° to 50°C minimum Operating humidity: 5% to 95%, non-condensing
Dimensions	4.8 x 3.8 in (12.2 x 9.6 cm) card edge (Mounting bracket, 1.2 x 12.1 x 0.9 cm)
Accessories	Software: Driver CD-ROM disc for Windows 98, ME, NT, 4.0, 2000, 2003 Server, XP, Vista, and Linux 2.4 Manual: Instruction Manual Contained on CD ROM

Figure 4. Mlport Serial Card Specifications

Chapter 2: Serial Card Setup

The following Serial Card Setup section applies to the following PCI cards:

- 3PCIU1 one port optically isolated PCI serial card
- 3PCIU2 two port optically isolated PCI serial card
- 3PCIU4 four port optically isolated PCI serial card
- 3PCIU2 two port non-isolated PCI serial card
- 3PCIU4 four port non-isolated PCI serial card
- 3PCIU8 eight port non-isolated PCI serial card

Any deviations from the procedure for specific models are noted.

Pre-Setup Steps

Your serial card has been tested for proper operation before packaging and shipping. It should be in perfect mechanical and electrical condition upon receipt.

ESD Precautions

To ensure a successful installation and setup it is important that you follow the standard ESD precautions outlined below:

**CAUTION:**

This is an Electrostatic Sensitive Device. Use ESD precautions for safe handling.

Before removing the card from the anti-static protective packaging:

- *Discharge any static electricity buildup on your body by touching a large grounded metal surface or the metal chassis on equipment connected to earth ground by a 3-wire power cord. Use of a grounding wrist strap is recommended.*
- *Avoid touching the gold connectors or other parts on the card except when necessary to set the configuration DIP switches.*
- *Remove AC power from the computer before inserting the card*

Initial Configuration

The ports in your Mlport card are normally pre-configured for RS-232 operation. To ensure the card is configured correctly for your desired operating mode, you will have to check and/or set the three operating mode DIP switches on the card. If you are configuring for RS-485 Mode you also may have to set up the RTS Control parameter in the device driver.

Note: Refer to Chapter 4 for information on Setting Driver Options.

Overview of Operational Modes

RS-232 Mode

In RS-232 Mode MIport serial ports function as buffered standard PC serial ports and operate as DTEs (Data Terminal Equipment). RS-232 interfaces are commonly used for communications with modems, serial printers, and computer-controlled devices such as security equipment, bar code scanners and point-of-sale devices.

For most MIport models, RS-232 Mode supports eight single-ended signal lines and signal ground (GND) including transmit (TD), receive (RD) and six hardware handshake lines (DTR, DSR, RTS, CTS, DCD, RI). The only exception to this is the MIport Model 3PCIU4 card, which supports TD, RD, RTS, CTS and GND.

RS-422 Mode

In RS-422 mode MIport serial ports provide two sets of differential signal pairs (TD and RD) and signal ground for each port. The RS-422 standard uses balanced differential drivers and receivers for each signal. This facilitates greater communication distances than unbalanced systems such as RS-232. In RS-422 mode the transmitter and receiver are always enabled (TX ON, RX ON).

RS-422 operation is suitable for interconnecting a computer and one device for full duplex (point-to-point) bi-directional communication, or a computer and several devices for unidirectional (point-to-multipoints) communication. RS-422 interfaces are commonly used for video editing/control, camera control, electronic signage, television studio/satellite dish control, performance lighting and audio equipment control.

RS-485 Mode

In RS-485 Mode MIport cards provide RS-485 interfaces which operate with the same signals and signal levels as RS-422. RS-485 interfaces differ from RS-422 in that they allow multiple devices to share the same communication link using half duplex (2-wire) or full duplex (4-wire) connections. Since it is possible to have more than one transmitter connected to the media, transmitters must be enabled only while sending data, and tri-stated at all other times so other devices can use the wire pair. MIport cards automatically enable the transmitter at the appropriate time using Automatic Send Data Control, based on the contents of the output buffer. When the buffer has data to send, the transmitter is enabled (TX SD). When all data in the buffer has been sent, the transmitter is disabled and tri-stated to a high impedance state.

In half-duplex operation, the receiver is disabled during transmit (RX \overline{SD}), and enabled when not transmitting. In full-duplex operation the receiver is always enabled (RX ON). Since RS-485 transmitters are tri-stated when not transmitting, the receive inputs must be biased to ensure the media floats in the Mark state so that the first Space state is detected correctly at the start of the next transmission.

These serial cards incorporate the necessary biasing to accommodate up to 32 standard nodes. (Typical input resistance (Rin) for each load is 12k Ω). Provisions are made for custom biasing and/or termination.

Note: For more information on RS-485 Mode refer to Chapter 6

Operating Mode Selection

The hardware address and IRQ for the serial card is set by the Windows Operating System using driver information files and the Plug and Play OS.

The Operating Mode is set using DIP switches, Device Manager Driver Settings and by your cable connections and software. Each port on a Mport card has an associated DIP switch to set its operating mode. The port number associated with the DIP switch is clearly silk screened on the printed circuit board.

Note: Refer to Appendix x for DIP switch locations on various Mport cards.

Setting the DIP Switches on RS-232/422/485 Ports

Set the DIP switches to configure the desired operating mode as follows:

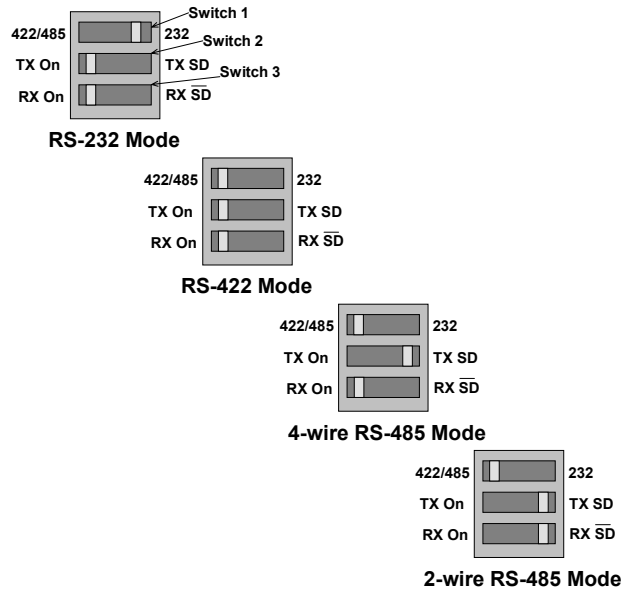

Figure 5. RS-232/422/485 DIP Switch Settings.

DIP Switch 1 (RS-232/422/485 ports)

The top DIP switch (1) configures the port for RS-232 or RS-422/485 operation. This switch is the only one that is required to be set for RS-232 operation. The positions of switches 2 and 3 do not matter when switch 1 is set for RS-232 operation.

DIP Switch 2 (RS-232/422/485 ports)

The middle DIP switch (2) configures the port for RS-485 or RS-422 operation. For RS-422 operation (which uses two wire pairs and sends point-to-point or point-to-multipoints) the transmitter can be enabled all the time. Placing the middle DIP switch in the TX ON position accomplishes this.

For RS-485 operation the middle DIP switch is placed in the TX SD position. In this position the transmitter is only enabled when data is being sent. The transmitter is tri-stated when not sending data, allowing other transmitters on the communications line to transmit without interference.

DIP Switch 3 (RS-232/422/485 ports)

The bottom DIP switch (3) configures the port for half-duplex (two-wire) RS-485 operation or full-duplex (four wire) RS-422/RS-485 operation. Placing the bottom DIP switch in the RX ON position configures the port for four wire operation. In this mode the receiver is continuously enabled, allowing it to receive all data on the communications line. Since the transmitter sends data on the other wire pair the port does not receive its own transmissions.

Placing the bottom DIP switch in the RX \overline{SD} position configures the port for two wire operation. In this mode the transmitter and receiver are connected to the same wire pair. The receiver is disabled when its transmitter is sending, preventing the port from receiving its own data.

Setting the DIP Switches on RS-422/485 Only Ports

The 3PCIU4 MIport card provides a combination of RS-232/422/485 and RS-422/485 only ports. Ports that do not include RS-232 operation use double DIP switches rather than triple DIP switches. These DIP switches operate the same as the two bottom DIP switches in the RS232/422/485 ports

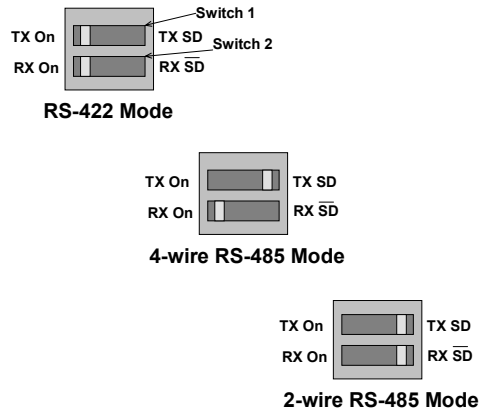

Figure 6. RS-422/485 only DIP Switch Settings

DIP Switch 1 (RS-422/485 only)

The top DIP switch (1) configures the port for RS-485 or RS-422 operation. For RS-422 operation (which uses two wire pairs and sends point-to-point or point-to-multipoints) the transmitter can be enabled all the time. Placing the middle DIP switch in the TX ON position accomplishes this.

For RS-485 operation the middle DIP switch is placed in the TX \overline{SD} position. In this position the transmitter is only enabled when data is being sent. The transmitter is tri-stated when not sending data, allowing other transmitters on the communications line to transmit without interference.

DIP Switch 2 (RS-422/485 only)

The bottom DIP switch (2) configures the port for half-duplex (two-wire) RS-485 operation or full-duplex (four wire) RS-422/RS-485 operation. Placing the bottom DIP switch in the RX ON position configures the port for four wire operation. In this mode the port's receiver is continuously enabled, allowing it to receive all data on the communications line. Since the port's transmitter sends data on the other wire pair the port does not receive its own transmissions.

Placing the bottom DIP switch in the RX \overline{SD} position configures the port for two wire operation. In this mode the port's transmitter and receiver are connected to the same wire pair. The receiver is disabled when its transmitter is sending, preventing the port from receiving its own data.

Installing the Serial Card



CAUTION:

This is an Electrostatic Sensitive Device. Use ESD precautions for safe handling.

Before removing the card from the anti-static protective packaging:

- Discharge any static electricity buildup on your body by touching a large grounded metal surface or the metal chassis on equipment connected to earth ground by a 3-wire power cord. Use of a grounding wrist strap is recommended.*
- Avoid touching the gold connectors or other parts on the card except when necessary to set the configuration DIP switches.*
- Remove AC power from the computer before inserting the card*

1. Shut down your computer.
2. Unplug the power cord to remove power to prevent accidentally turning on the computer during installation.
3. Remove the cover of the computer.
4. Locate an empty PCI expansion slot.
5. Remove the expansion slot cover. Save the retaining screw.
6. Ground yourself to the computer chassis before and while inserting the card.
7. Install the card into the unused slot. Be certain that the card is inserted completely (fully seated) in the slot.
8. Secure the card with the mounting screw from Step 5.
9. Replace the cover; plug in the power cord.
10. Connect your cables.
11. Power up the system.
12. Install the drivers as described in Chapter 3.

Chapter 3: Driver Software Installation

Installing Windows Vista Driver Software

Installation of the MIport driver software on Windows Vista is a three-step process:

1. Windows Vista searches and identifies new hardware that has been installed.
2. You use the Found New Hardware Wizard to install the driver software for the card.
3. You use the Found New Hardware Wizard to install the software for each port on the card.

There are several possible methods for installing the software. The procedure outlined here is recommended for most situations.

Note: If at some point in the future, you want to update these drivers, remove the old drivers before installing the new version. Refer to Chapter 6 for driver removal procedures.

Pre-Installation Steps

1. Configure the port(s) on the card for the desired mode (RS-232, RS-422 or RS-485) using the three DIP switches on the card.
2. If configuring for RS-422 or RS-485 Modes, and bias or termination resistors are needed, add them at this time.

Note: Refer to Chapter 2 of information on DIP switch settings and bias/termination resistors.

3. Install the card in the slot. Use appropriate ESD handling precautions.
4. Power up the computer
5. Insert your driver disc in the CD-ROM drive.

Using the Found New Hardware Wizard

Windows will detect the PCI card and start the **Found New Hardware Wizard** to begin the driver installation. The following dialog box will appear:

Drive software (on CD-ROM) is provided with your MIport card. Do not connect to Windows Update to search for software.

6. Select **No, not at this time** and click **Next**.

PCI Card Software Installation

Once the new hardware has been detected, the wizard will proceed to install the software for the card. The following dialog box will appear:

7. To begin the installation of the software for the PCI card, click **Install the software automatically**. Click **Next**.

Windows will find the appropriate files on the CD, then display a dialog box concerning Window Logo testing for Vista. This feature of Vista simply indicates that these drivers have not yet undergone the Microsoft testing procedure required to use the Windows Vista Logo on the packaging. Driver compatibility is not affected.

8. Click **Continue Anyway**.

A dialog box will appear indicating the software installation is proceeding.

9. When the **Completing the Found New Hardware Wizard** dialog appears, click **Finish**.

Port Driver Installation

The Welcome to the Found New Hardware Wizard will appear again, indicating it has detected a port on the PCI card. Repeat the steps above to install the port driver software.

If the card you are installing has more than one port, Windows Vista will find each port in sequence and re-launch the **Found New Hardware Wizard** for each port. Repeat the previous steps for each port.

Checking the Driver Installation

You may want to check to verify that the new B&B COM ports are now available.

1. From the Windows Desktop, click **Start** → **Control Panel** → **System and Maintenance** → **Device Manager**
2. In the **Device Manager**, click **Multi-port serial adapters**.

All serial adapter cards should appear in the list. Additional information about the cards can be obtained by double-clicking the name of the card.

3. Click **Ports (COM & LPT)**

All installed ports should appear in the list. The COM port number assigned to each port will be shown.

Installing Windows XP Professional Driver Software

Installation of the MIport driver software on Windows XP Professional is a three-step process:

1. Windows XP searches for and identifies new hardware that has been installed.
2. You use the Found New Hardware Wizard to install the driver software for the card.
3. You use the Found New Hardware Wizard to install the software for each port on the card.

There are several possible methods for installing the software. The procedure outlined here is recommended for most situations.

Note: If at some point in the future, you want to update these drivers, remove the old drivers before installing the new version. Refer to Chapter 6 for driver removal procedures.

Windows Settings

Windows Classic settings are used in the following screenshots. To configure Windows XP for Windows Classic settings, position the mouse pointer over the **Taskbar** (at the bottom of the Desktop), then right click. On the menu that appears, click **Properties**. The **Taskbar and Start Menu Properties** dialog will appear. Click the **Start Menu** tab, then click **Classic Start Menu**. Click **OK**.

Pre-Installation Steps

4. Configure the port(s) on the card for the desired mode (RS-232, RS-422 or RS-485) using the three DIP switches on the card.
5. If configuring for RS-422 or RS-485 Modes, and bias or termination resistors are needed, add them at this time.

Note: Refer to Chapter 2 of information on DIP switch settings and bias/termination resistors.

6. Install the card in the slot. Use appropriate ESD handling precautions.
7. Power up the computer
8. Insert your driver disc in the CD-ROM drive.

Using the Found New Hardware Wizard

Windows will detect the PCI card and start the **Found New Hardware Wizard** to begin the driver installation. The following dialog box will appear:



Figure 7. The XP Found New Hardware Wizard

Driver software (on CD-ROM) is provided with your MIport card. Do not connect to Windows Update to search for software.

9. Select **No, not this time** and click **Next**.

PCI Card Software Installation

Once the new hardware has been detected, the wizard will proceed to install the software for the card. The following dialog box will appear:

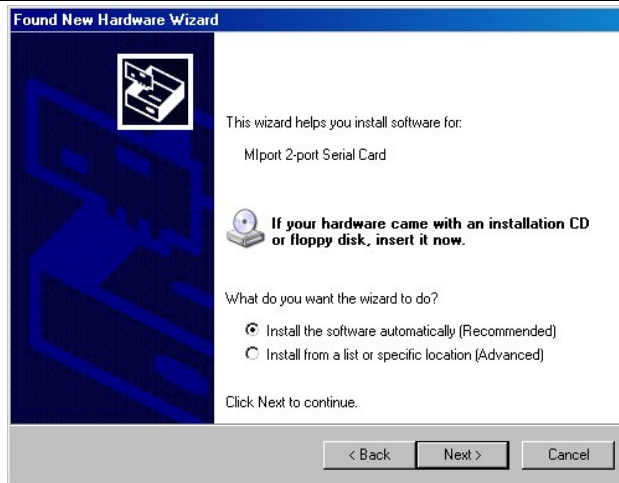

Figure 8. The “Install the Card Software Automatically” Dialog

10. To begin the installation of the software for the PCI card, click **Install the software automatically**. Click **Next**.

Windows will find the appropriate files on the CD, then display a dialog box concerning Windows Logo testing for XP. This feature of XP simply indicates that these drivers have not yet undergone the Microsoft testing procedures required to use the Windows XP Logo on the packaging. Driver compatibility is not affected.



Figure 9. Windows Logo Testing Screen

11. Click **Continue Anyway**.

A dialog box will appear indicating the software installation is proceeding.

12. When the **Completing the Found New Hardware Wizard** dialog appears, click **Finish**.

Port Driver Installation

The Welcome to the Found New Hardware Wizard will appear again, indicating it has detected a port on the PCI card. Repeat the steps above to install the port driver software.

If the card you are installing has more than one port, Windows XP will find each port in sequence and re-launch the **Found New Hardware Wizard** for each port. Repeat the previous steps for each port.

Checking the Driver Installation

You may want to check to verify that the new B&B COM ports are now available.

1. From the Windows Desktop, click **Start** → **Settings** → **Control Panel** → **System**
2. On the **System Properties** dialog box, click the **Hardware** tab, then click the **Device Manager** button. The **Device Manager** window will appear:

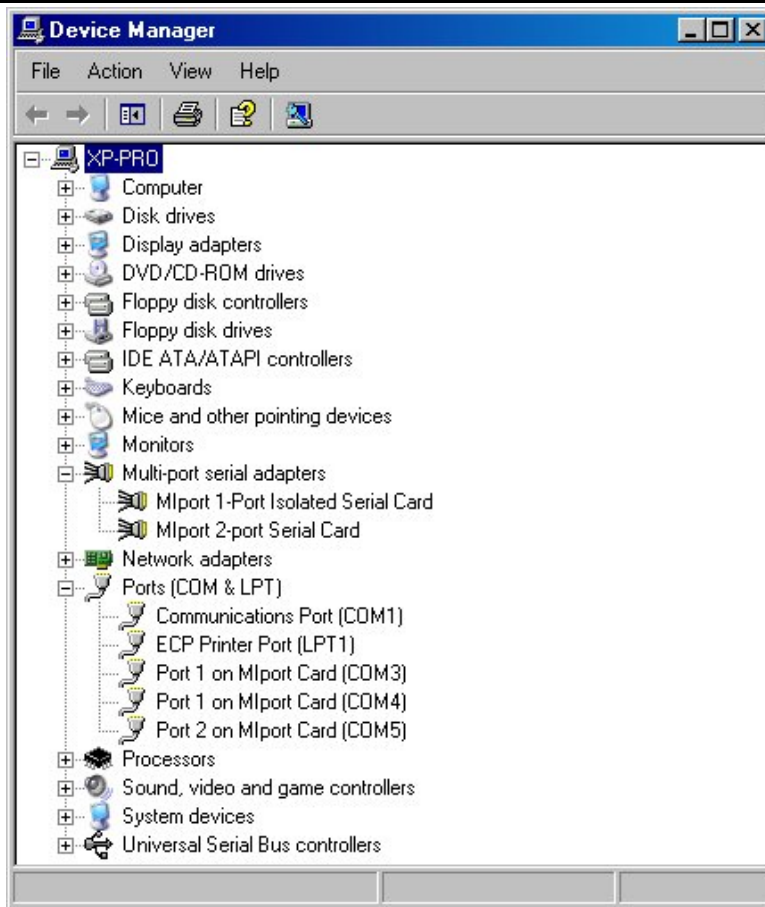

Figure 10. The Device Manager Window

3. In the **Device Manager**, click **Multi-port serial adapters**.

All serial adapter cards should appear in the list. Additional information about the cards can be obtained by double-clicking the name of the card.

4. Click **Ports (COM & LPT)**

All installed ports should appear in the list. The COM port number assigned to each port will be shown.

Installing Windows 2000 Professional Driver Software

Installation of the MIport driver software on Windows 2000 Professional is a three-step process:

1. Windows searches for and identifies new hardware that has been installed.
2. You use the Found New Hardware Wizard to install the driver software for the card.
3. You use the Found New Hardware Wizard to install the software for each port on the card.

There are several possible methods for installing the software. The procedure outlined here is recommended for most situations.

Note: If at some point in the future, you want to update these drivers, remove the old drivers before installing the new version. Refer to Chapter 6 for driver removal procedures.

Windows Settings

Windows Classic settings are used in the following screenshots. To configure Windows for Windows Classic settings, position the mouse pointer over the **Taskbar** (at the bottom of the Desktop), then right click. On the menu that appears, click **Properties**. The **Taskbar and Start Menu Properties** dialog will appear. Click the **Start Menu** tab, then click **Classic Start Menu**. Click **OK**.

Pre-Installation Steps

4. Configure the port(s) on the card for the desired mode (RS-232, RS-422 or RS-485) using the three DIP switches on the card.
5. If configuring for RS-422 or RS-485 Modes, and bias or termination resistors are needed, add them at this time.

Note: Refer to Chapter 2 of information on DIP switch settings and bias/termination resistors.

6. Install the card in the slot. Use appropriate ESD handling precautions.
7. Make sure PnP OS is set in the BIOS.
8. Power up the computer
9. Insert your driver disc in the CD-ROM drive.

Using the Found New Hardware Wizard

Windows will detect the PCI card and start the **Found New Hardware Wizard** to begin the driver installation. The following dialog box will appear:



Figure 11. The Windows 2000 Add New Hardware Wizard

The driver installation goes through several steps, after finding the driver files. The first part installs the driver for the card, then after Finish, the second part installs the serial driver for the COM port. Do not remove the CD until completed.

10. Click **Next**.

PCI Card Software Installation

Once the new hardware has been detected, the wizard will proceed to install the software for the card. The following dialog box will appear:

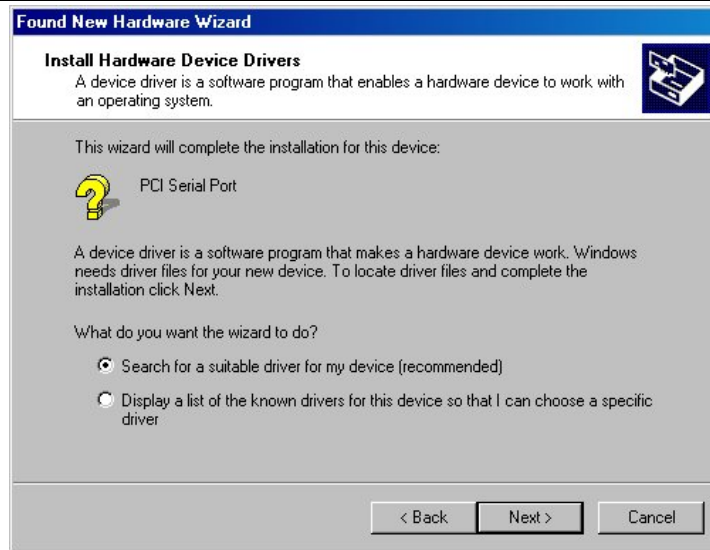

Figure 12. The “What do you want Windows to do?” dialog

11. To begin the installation of the software for the PCI card, click **Search for a suitable driver for my device**, then click **Next**.

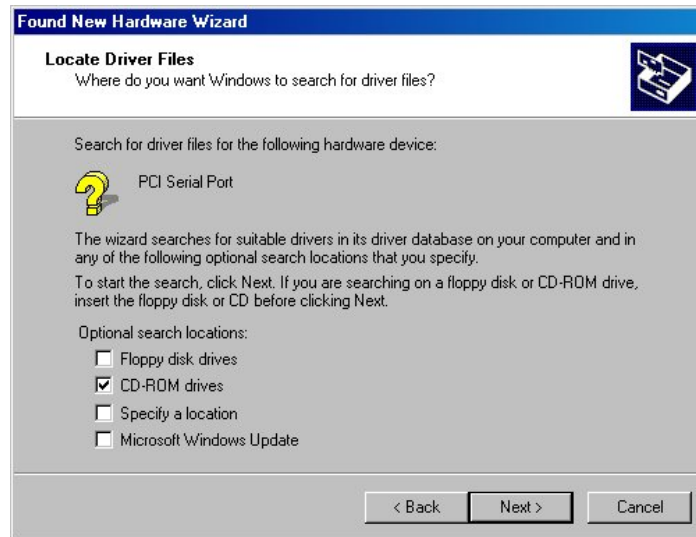

Figure 13. The “Windows will search for new driver” dialog

12. Select **CD-ROM Drive**, then click **Next**.

Windows will find the appropriate files on the CD.

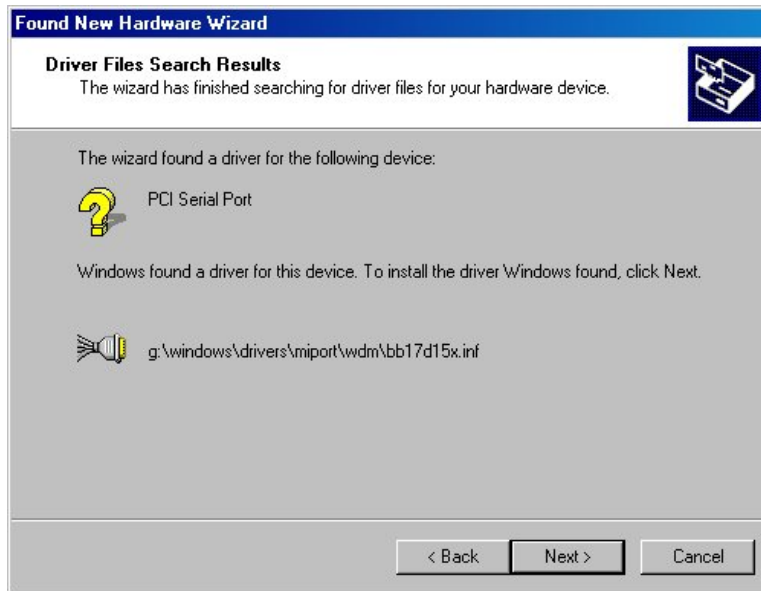

Figure 14. The “Windows driver file search for the device” dialog

13. To begin the installation of the software for the PCI card, click **Next**.

Windows will display the **Digital Signature Not Found** dialog box. This feature simply indicates that these drivers have not yet undergone the Microsoft testing procedures required to use the Windows logo on the packaging. Driver compatibility is not affected.

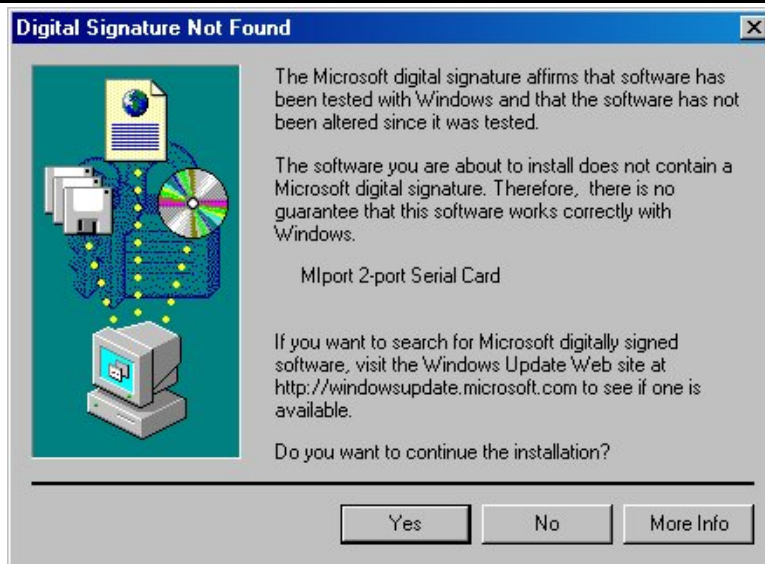

Figure 15. The Digital Signature Not Found Dialog

14. Click **Yes**

A dialog box will appear indicating the software installation is proceeding.

15. When the **Completing the Found New Hardware Wizard** dialog appears, click **Finish**.

Port Driver Installation

The Add New Hardware Wizard will appear again, indicating it has detected a port on the PCI card. Repeat the steps above to install the port driver software.

If the card you are installing has more than one port, Windows will find each port in sequence and re-launch the **Found New Hardware Wizard** for each port. Repeat the previous steps for each port.

Checking the Driver Installation

You may want to check to verify that the new B&B COM ports are now available.

1. From the **Windows Desktop**, click **Start** → **Settings** → **Control Panel** → **System**
2. On the **System Properties** dialog box, click the **Hardware** tab, then click the **Device Manager** button. The **Device Manager** window will appear:

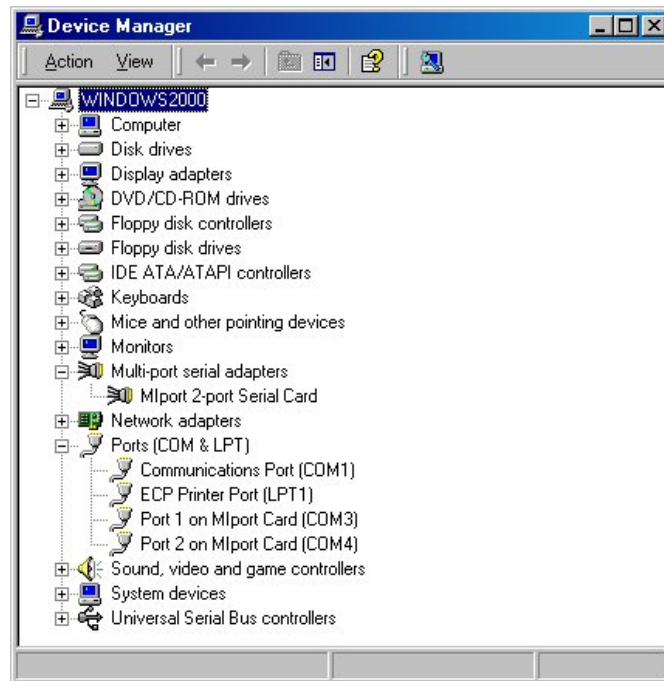

Figure 16. System Properties Screen

3. In the **Device Manager**, click **Multi-port serial adapters**
All serial adapter cards should appear in the list. Additional information about the cards can be obtained by double-clicking the name of the card.
4. Click **Ports (COM & LPT)**
All installed ports should appear in the list. The COM port number assigned to each port will be shown.

Installing Windows 98 or ME Driver Software

Installation of the MIport driver software on Windows 98 is a three-step process:

1. Windows searches for and identifies new hardware that has been installed.
2. You use the Found New Hardware Wizard to install the driver software for the card.
3. You use the Found New Hardware Wizard to install the software for each port on the card.

There are several possible methods for installing the software. The procedure outlined here is recommended for most situations.

Note: If at some point in the future, you want to update these drivers, remove the old drivers before installing the new version. Refer to Chapter 6 for driver removal procedures.

Windows Settings

Windows Classic settings are used in the following screenshots. To configure Windows for Windows Classic settings, position the mouse pointer over the **Taskbar** (at the bottom of the Desktop), then right click. On the menu that appears, click **Properties**. The **Taskbar and Start Menu Properties** dialog will appear. Click the **Start Menu** tab, then click **Classic Start Menu**. Click **OK**.

Pre-Installation Steps

1. Configure the port(s) on the card for the desired mode (RS-232, RS-422 or RS-485) using the three DIP switches on the card.
2. If configuring for RS-422 or RS-485 Modes, and bias or termination resistors are needed, add them at this time.

Note: Refer to Chapter 2 of information on DIP switch settings and bias/termination resistors.

3. Install the card in the slot. Use appropriate ESD handling precautions.
4. Make sure PnP OS is set in the BIOS.
5. Power up the computer
6. Insert your driver disc in the CD-ROM drive.

Using the Add New Hardware Wizard

Windows will detect the PCI card and start the **Add New Hardware Wizard** to begin the driver installation. The following dialog box will appear:



Figure 17. The Add New Hardware Wizard dialog

The driver installation goes through several steps, after finding the driver files. The first part installs the driver for the card, then after Finish, the second part installs the serial driver for the COM port. Do not remove the CD until completed.

7. Click **Next**.

PCI Card Software Installation

Once the new hardware has been detected, the wizard will proceed to install the software for the card. The following dialog box will appear:



Figure 18. The “What do you want Windows to do?” dialog

8. To begin the installation of the software for the PCI card, click **Search for the best driver for your device**, then click **Next**.



Figure 19. The “Windows will search for new drivers” dialog

9. Select **“Specify a location”** and choose the **E:\ Windows\Drivers\MIport\98_ME** folder.

NOTE: In Windows ME you will need to select the Driver from this folder:
E:\ Windows\Drivers\MIport\98_ME

Windows will find the appropriate files on the CD.



Figure 20. The “Windows driver file search for the device” dialog

10. Click **Next**.



Figure 21. The “Windows has finished installing” dialog

11. Click **Finish**. Installation will complete automatically.

Port Driver Installation

The Add New Hardware Wizard will appear again, indicating it has detected a port on the PCI card. Repeat the steps above to install the port driver software.

If the card you are installing has more than one port, Windows will find each port in sequence and re-launch the **Found New Hardware Wizard** for each port. Repeat the previous steps for each port.

Checking the Driver Installation

You may want to check to verify that the new B&B COM ports are now available.

1. From the Windows Desktop, click Start → Settings → Control Panel → System
2. On the **System Properties** dialog box, click the **Hardware** tab, then click the **Device Manager** button. The **Device Manager** window will appear:

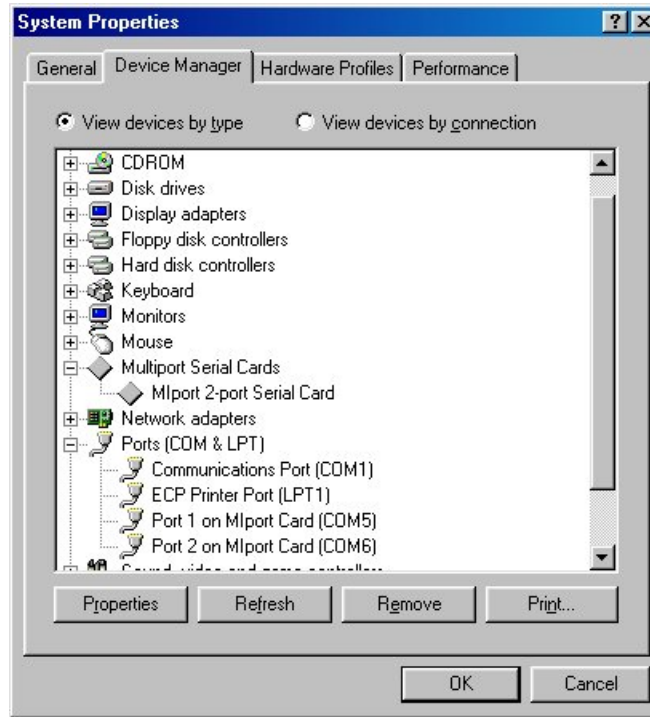

Figure 22. System Properties Screen

3. In the **Device Manager**, click **Multiport Serial Cards**

All serial adapter cards should appear in the list. Additional information about the cards can be obtained by double-clicking the name of the card.

4. Click **Ports (COM & LPT)**

All installed ports should appear in the list. The COM port number assigned to each port will be shown.

Installing Windows NT Driver Software

Installation of the MIport driver software on Windows NT is a two-step process:

1. Installing the driver software.
2. Configuring the ports

Note: If at some point in the future, you want to update these drivers, remove the old drivers before installing the new version. Refer to Chapter 6 for driver removal procedures.

Windows Settings

Windows Standard settings are used in the following screenshots. To configure Windows NT for Windows Standard settings, open the **Control Panel** and double-click the **Display** icon. Click the **Appearance** tab and select Windows Standard under **Scheme**, then click **OK**.

Pre-Installation Steps

1. Configure the port(s) on the card for the desired mode (RS-232, RS-422 or RS-485) using the three DIP switches on the card.
2. If configuring for RS-422 or RS-485 Modes, and bias or termination resistors are needed, add them at this time.

Note: Refer to Chapter 2 of information on DIP switch settings and bias/termination resistors.

3. Install the card in the slot. Use appropriate ESD handling precautions.
4. Power up the computer and login as the Administrator, or as a user that is a member of the Administrators group.
5. Insert your driver disc in the CD-ROM drive.

Installing the Driver Software

The driver software only has to be installed once regardless of how many MIport cards and/or ports are added to the system. If the driver software already has been installed you can go directly to **Configuring the Serial Ports** later in this section.

1. Using **Windows NT Explorer** find the NT **install.exe** file on the MIport installation CD. The file is located on the CD-ROM at:
E:\Windows\Drivers\MIport\NT4

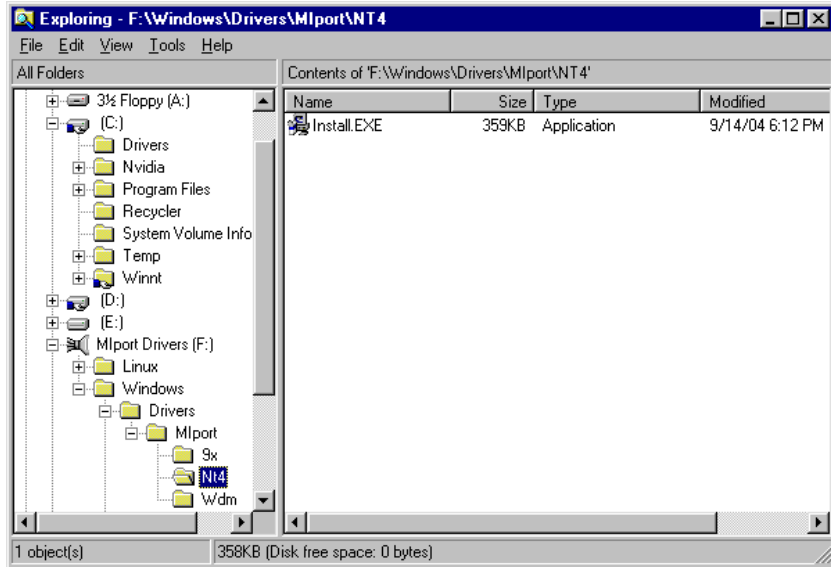

Figure 23. The Install.exe file in Windows NT Explorer

2. Double-click the **install.exe** file. The **MIport Driver v1.0.0 for Windows NT 4.0 Installation Welcome** dialog will appear.

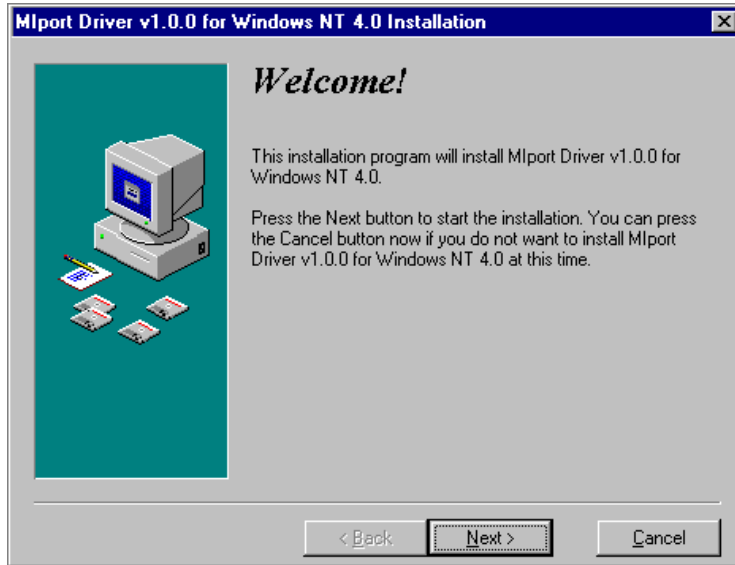

Figure 24. The NT Driver Installation Welcome Dialog

3. Click **Next** on the **Welcome** dialog. The **Copyright Information** dialog will appear.
4. Click **Next** on the **Copyright Information** dialog. The **Select Destination Directory** dialog will appear.
5. Click **Next** to install the files in the suggested directory.



Figure 25. The Select Destination Directory Dialog

The **Ready to Install!** dialog will appear.

6. Click **Next**. The **Installation Completed!** dialog will appear.
7. Click **Finish**. The driver software is now installed.

Configuring the Serial Ports

Before using the serial ports, they must be configured.

1. Open the **Control Panel**.

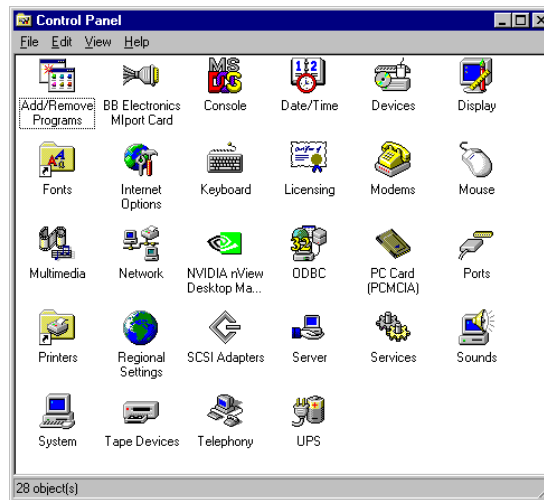

Figure 26. The NT Control Panel Showing the BB Electronics Mport Card Applet Icon

2. Double-click the **BB Electronics Mport Card** applet icon. The **B&B Electronics Multiport Boards** dialog will appear showing the port(s) on the Mport card as not assigned.
3. Select a name for the first port from the dropdown list.
Make a Note: If more than one Mport card is installed, select the board in the Boards dropdown list first.

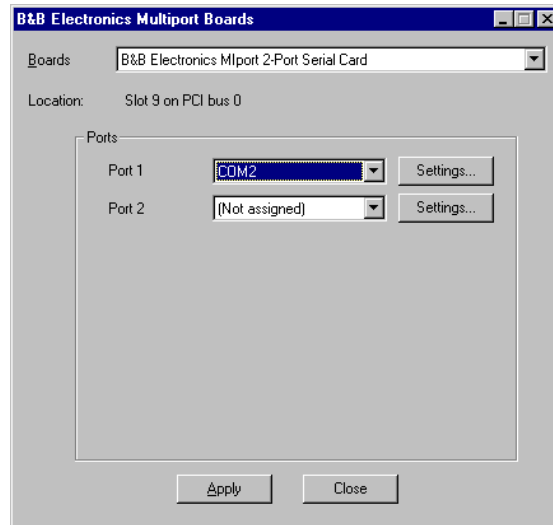

Figure 27. Selecting Port Names

4. Click **Settings** for the port.
5. In the **Communications Port Settings** dialog that appears set the bits per second, data bits, parity, stop bits and flow control if they need to be changed from the default values.

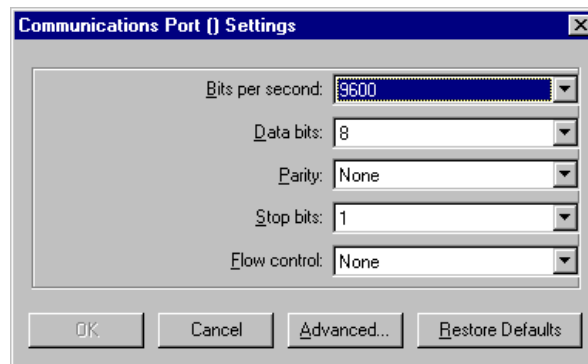

Figure 28. Communications Port Settings

6. If you change any parameters the **OK** button will become available. Click **OK** to accept the changes.
7. Click **Advanced**. The Advanced Setting dialog will appear.

8. In the **Advanced Settings** dialog set the **Receive buffer: Low**, **Transmit buffer: Low**, **RTS Control** and **Hardware handshaking Hysteresis level (characters)** as necessary.

Note: For more information on advanced settings refer to Chapter 4

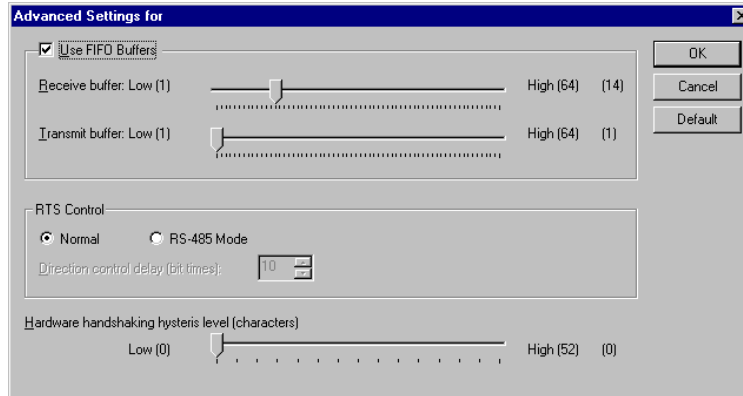

Figure 29. The Advanced Port Setting Dialog

9. Click **OK** to return to the **Communications Port Settings**.
10. Click **Cancel** to return to the **Assign Ports** dialog.
11. Repeat the procedure for any additional ports on the list.
12. Re-start your computer so the changes will take effect.

Note: After restarting the computer, you can check the Ports applet to make sure that the driver assigned the COMx names to the serial ports; however, you must not change the settings of the serial port within the Ports applet.

Chapter 4: Setting Driver Options

Configuring Port Settings (Does not apply to Windows NT.)

By entering the Properties dialog a variety of information can be obtained and several port parameters can be configured.

1. On the **Ports (COM & LPT)** list, double-click the name of the port to be configured.
2. On the **Port Properties** dialog, click the Port **Settings** tab.

The dialog will display the current settings for Bits per second, Data bits, Parity, Stop bits and Flow control. If necessary, change these settings to the required values.

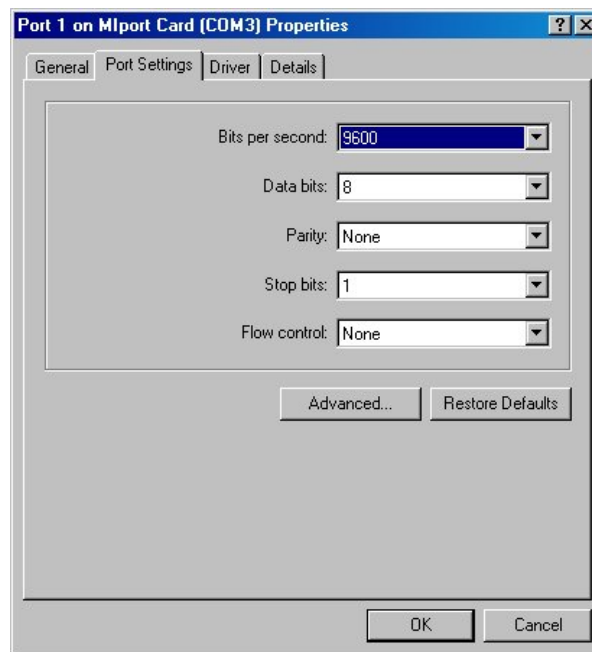

Figure 30. The Port Settings Dialog

3. Click **Advanced...**

The **Advanced Port Settings** dialog will appear. This screen allows you to set the Receive and Transmit FIFO buffer thresholds, RTS Control parameters, Hardware handshaking hysteresis level and the COM port name.

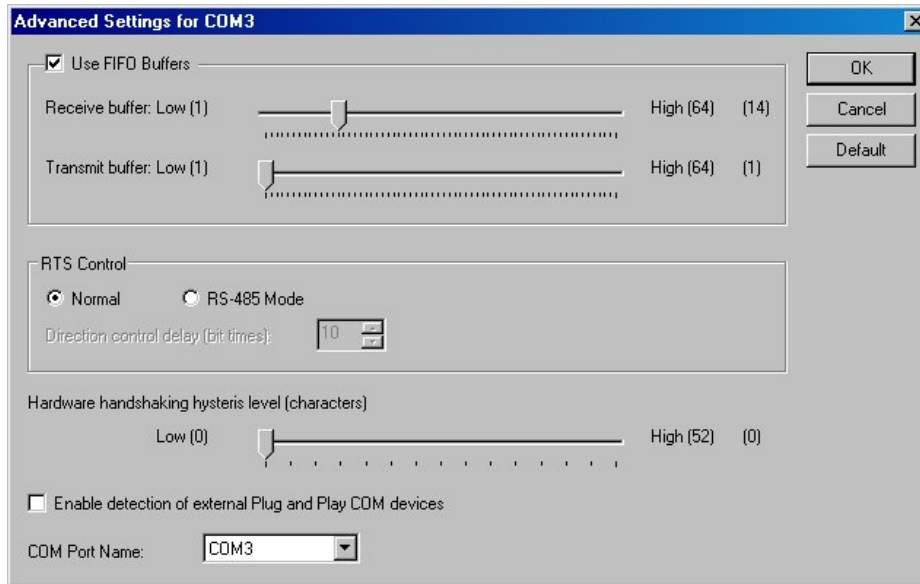

Figure 31. The Advanced Settings for COM# dialog

Setting the FIFO Buffers

MIport cards use UARTs that contain 64-byte transmit and receive FIFO (first in, first out) buffer registers. The transmit buffer holds the data to be sent; the receive buffer holds the data received.

The **Transmit buffer: Low** parameter in the **Advanced Port Settings** dialog allows you to set the minimum value at which the UART will request more data from the computer. As the MIport card is transmitting data, the number of bytes left in the transmit buffer will decrease. When the buffer reaches the value set, the UART will request more data from program memory. This is intended to optimize the throughput of the data. Typically this parameter is set at zero and usually does not have to be changed.

The **Receive buffer: Low** parameter in the Advance Port Settings dialog allows you to set the value at which the UART will request that the computer read the data that has been received. As the MIport card is receiving data the contents of the receive buffer increases, when it reaches the value set, the

UART will request that the computer transfer the contents of the buffer to program memory. This is intended to optimize the throughput of the data. The default value is 14. Usually this parameter does not have to be changed.

Setting the RTS Control Parameter

1. Set **RTS Control** to **Normal** for RS-232; set **RTS Control** to **RS-485 Mode** for 2-wire or 4-wire RS-485 operation. Either setting can be used for RS-422.

Typically the COM parameters set in this dialog box are overridden by the software application.

Note: For proper operation the DIP switches on the PCI card must be set for the same mode. Refer to Chapter 2 for more information on configuring the DIP switches.

2. The **Direction control delay (bit times)** box allows you to set the length of time the Transmit driver continues to be enabled after the last bit of data in the transmit register has been sent. The purpose of this setting is to maintain the transmission line in a known (idle) state until the data has reached its destination. If the line is released too soon it can pick up noise that could cause problems on the communications system. This parameter is preset to a value of 10 bit times and typically will not have to be changed. For longer transmission lines this value may have to be increased.

Setting the Hardware Handshaking Level

The **Hardware handshaking Hysteresis level (characters)** parameter allows you to set how long the local UART will continue to accept data after its receive buffer has reached the point at which it asks the computer to transfer the data to program memory. When this point is reached the UART de-asserts the RTS hardware handshake line (which is connected to the remote UART's CTS line), stopping the remote device from sending data until its CTS line is re-asserted. This will occur when the local receive FIFO buffer has been cleared. The default value for this parameter is 0. Typically this value will not need to be changed.

Changing the COM Port Name/Number

1. To change the COM port number assigned to the port, click the **COM Port Name** arrow and select the new **COM Port Name** from the list.

Available names for COM numbers are shown. Select a new number from those not “in use”. COM numbers from COM1 to COM256 may be available. COM numbers “in use” may be used by motherboard ports, modems, virtual COM ports for network serial server devices or FAX modems. Formerly installed USB to serial adaptors, PCI cards or other hardware may have reserved a COM number. The device may need to be added back to the system, then the software removed. Advanced editing of the registry may be required to clean up the problem. Special permissions are required with 2000 or XP.

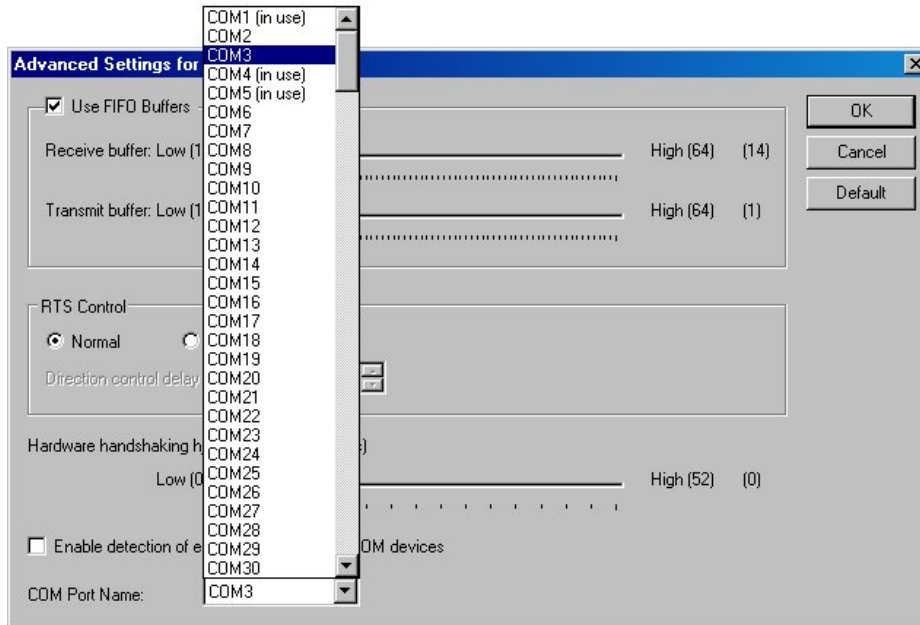

Figure 32. Changing the COM Port Name/Number

- After selecting a new COM name/number, Click **OK**, then click **OK** again on the **Settings** page.

After returning to the **Device Manager** screen, it should refresh automatically. The name/number of the port in the Device Manager list should now show the change.

Chapter 5: Installing Linux Driver Software

Installing Mlport Drivers in Linux

Note to the Editor(s): All commands and directories are case sensitive in Linux. When updating this section, be very careful about then things are uppercase or lowercase.

Installation of the Linux driver software for Mlport cards is a three-step process:

1. Preparing the Linux files
2. Compiling the driver
3. Installing the driver

Preparing the Linux Files

The following procedure assumes you have mounted your Mlport driver CD-ROM under /mnt/cdrom

1. Open a terminal window and execute the following steps at the command prompt.
2. Change to a user directory on your system:
cd /home/username
3. Untar the driver files
tar xzpf /mnt/cdrom/Linux/Drivers/Mlport-1.0.0.tar.gz

Compiling the Driver

Open a terminal window and execute the following steps at the command prompt to ompile and install the driver:

1. Change to installation directory:
cd /home/username/bbelec/drivers/Mlport

2. Remove any temporary files:

make clean

3. Make a dependency file:

make dep

4. Make the driver file:

make

Installing the Driver

1. If the user is not root, switch to the root user

su

2. Install the driver files as root

make install

```

[time@localhost Mport]$ ls -l
bb17d15x.c
bbmknod_csh
bbmknod_sh
Makefile
rc.bb17d15x
rc.serial
readme
[time@localhost Mport]$ make dep
Makefile:37: bb17d15x.dep: No such file or directory
gcc -MM -D__KERNEL__ -DMODULE -DLINUX -DKERNEL2_0 -DBBELEC -O2 -Wall -Wstrict-prototypes -fomit-frame-pointer -I/usr/src/linux-2.4.7-10/include -c bb17d15x.c > bb17d15x.dep
make: Nothing to be done for `dep'.
[time@localhost Mport]$ make
gcc -D__KERNEL__ -DMODULE -DLINUX -DKERNEL2_0 -DBBELEC -O2 -Wall -Wstrict-prototypes -fomit-frame-pointer -I/usr/src/linux-2.4.7-10/include -c bb17d15x.c
bb17d15x.c: In function `get_serial_info':
bb17d15x.c:1701: warning: assignment makes integer from pointer without a cast
[time@localhost Mport]$ su
Password:
[root@localhost Mport]# make install
install -d /lib/modules/2.4.7-10/kernel/drivers/char
install -c bb17d15x.o /lib/modules/2.4.7-10/kernel/drivers/char
chmod 0644 /lib/modules/2.4.7-10/kernel/drivers/char/bb17d15x.o
cp ./rc.bb17d15x /etc/rc.d
chmod 0755 /etc/rc.d/rc.bb17d15x
[root@localhost Mport]#

```

Figure 33. Building the Driver in a Terminal Window

3. Make the device nodes:
 - a. `./bbmknod_sh` if the system uses **sh** for its shell
 - b. `./bbmknod_csh` if the system uses a **c-shell** environments

4. Modify the startup script to automatically start the driver:

```
cp /home/username/bbelec/drivers/Mlport/rc.bb17d15x /etc/rc.d
```

WARNING: Do not overwrite `/etc/rc.d/rc.serial` if it already exists!

Note: These scripts will create the device nodes `/dev/tty/M0/` and `/dev/cum0` for each port, where the 0 is the number of the port.

If `/etc/rc.d/rc.serial` already exists append the commands from:

```
/home/username/bbelec/drivers/Mlport/rc.serial
```

to

```
/etc/rc.d/rc.serial
```

The commands in `/home/username/bbelec/drivers/Mlport/rc.serial` are:

```
#!/bin/sh  
if [ -f /etc/rc.d/rc.bb17d15x ]; then  
  sh /etc/rc.d/rc.bb17d15x  
fi
```

5. Restart the computer

```
/sbin/shutdown -r now
```

Note: Only the root user and members of the "uucp" group will have access to the driver. Add users to the "uucp" group as needed.

Checking the Driver Installation

Open a terminal window and execute the following steps at the command prompt to check the driver installation:

1. If the user is not root, then switch to the root user:

```
su
```

2. Check that the driver is running:

```
/sbin/lsmmod | grep bb17d15x
```

3. Switch from the root user back to the user

4. a. Copy **rc.bb15d15x**

```
cp /home/username/bbelec/drivers/MIport/rc.bb17d15x/etc/rc.d
```

- b. Modify or create **/etc/rc.serial** to call **/etc/rc.d/rc.bb.17d15x**

**WARNING: DO NOT OVERWRITE AN EXISTING
/etc/rc.serial**

If **/etc/rc.serial** already exists in **/etc/rc.d** then add the following commands to the end of the file:

```
if [ -f /etc/rc.d/rc.bb17d15x ]; then  
    sh /etc/rc.d/rc.bb17d15x  
fi
```

If **/etc/rc.serial** does not exist, then copy it with the following command:

```
cp /home/username/bbelec/drivers/MIport/rc.serial/etc/rc.d
```

- c. Modify **/etc/rc.d/rc.local** to call **/etc/rc.d/rc.serial**

If the following commands are not in **/etc/rc.d/rc.local**, then add them to the end of the file:

```
if [ -f /etc/rc.d/rc.serial ]; then  
    sh /etc/rc.d/rc.serial  
fi
```

5. Switch from the root user back to the user with the command:

```
exit
```

Using the Exar Serial GUI Example Application

The Exar Serial Test GUI is a program included on your MIport software CD that can be used to check the operation of your MIport card. The following procedure describes how to set up and run this application.

Preparing the Example Application Files

1. Open a terminal window and execute the following steps at the command prompt.
2. Change to a user directory on your system:
cd /home/username
3. Untar the driver files
tar xzpf /mnt/cdrom/Linux/Programs/exser.tar.gz
4. See **/home/username/GUI/INSTALL** for instructions on compiling and installing the application.

Running the Exar Serial Test GUI

5. To run the Exar Serial Test GUI:
 - a. Launch the application from a terminal window:
/home/username/GUI/exser/exser &
 - or
 - b. Edit the menu for your windows manager and add **/home/username/GUI/exser/exser** as an application.

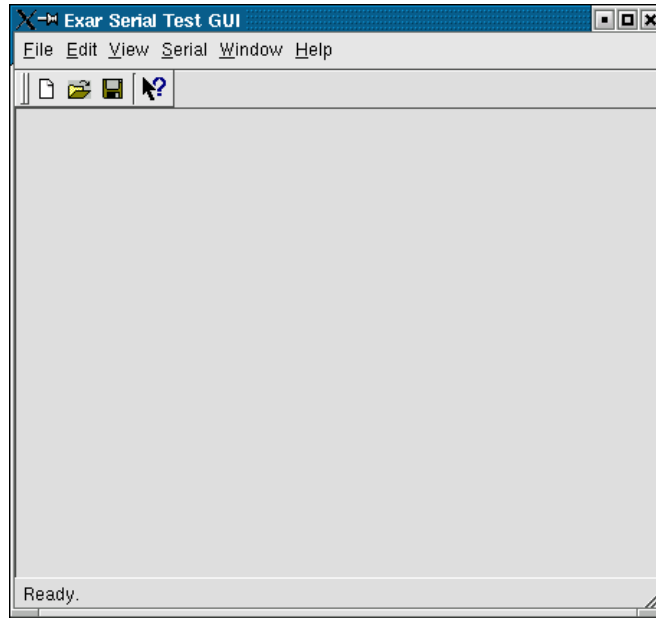

Figure 34. The Blank Application Window

- Click **File, Open**. The **Open Device** dialog will appear.

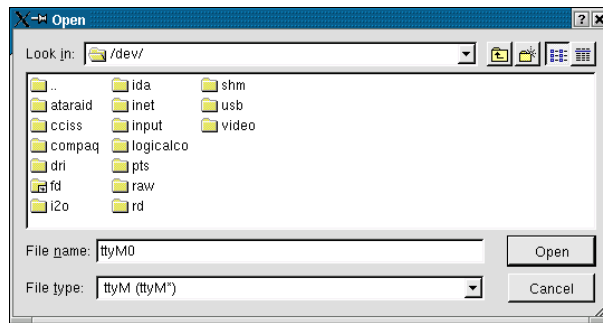

Figure 35. The Open device dialog box

- Type the name of the device in the File name box. The name will be ttyM0, ttyM1, etc. Click **Open**.

The screen will change from gray to white and the name of the file will appear at the top of the screen.

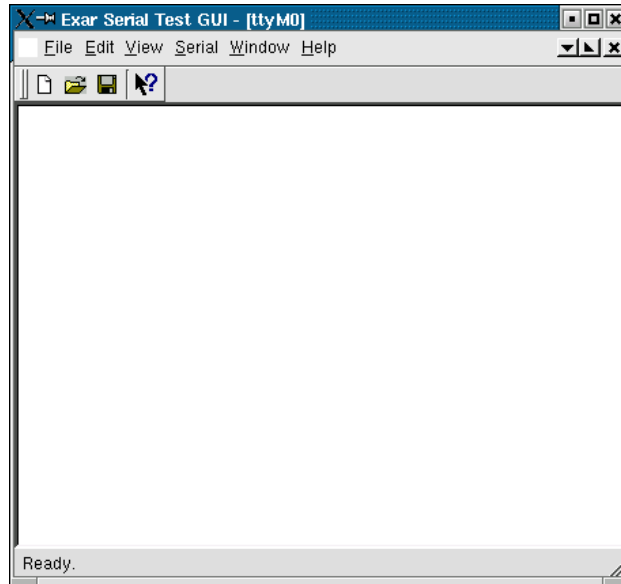

Figure 36. The Open Application Window

Configuring Port Settings

1. Click Serial, Port Settings. The Serial port parameters dialog will appear. The dialog will display the current serial port settings. Enter the parameters required for your application.

Note: Refer to Chapter 4 for detailed explanations of serial port settings.

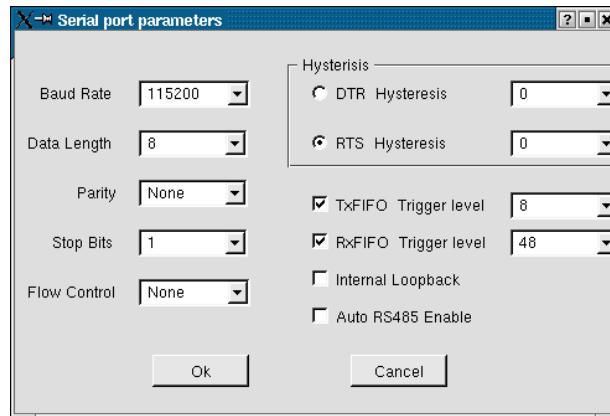

Figure 37. The Exar Serial Port Parameters dialog

Chapter 6: Removing Drivers, Ports and Cards

You may need to remove the card from your system or remove the current driver before installing a driver upgrade. The following sections describe removal procedures.

Removing MIport Cards from Win98/ME/2000/2003 Server/XP/Vista

Uninstalling the MIport Card

1. In the **Device Manager**, under **Multi-port serial adapters**, right-click the card to be uninstalled. **NOTE:** The card must still be physically installed in the computer, otherwise it will not show up in the Device Manager.
2. In the pop-up menu that appears, click **Uninstall**.
3. On the **Confirm Device Removal** dialog that appears, click **OK**.
4. After a few seconds the dialog will disappear. In the **Device Manager** the listings for the card (under **Multi-port serial adapters**) and all associated COM ports (under **Ports (COM & LPT)**) will be gone.
5. Physically remove the MIport card from the computer.

Uninstalling the COM ports

1. In the **Device Manager**, under **Ports (COM & LPT)**, right-click the COM port to be uninstalled.
2. On the **Confirm Device Removal** dialog that appears, click **OK**.
3. After a few seconds the dialog will disappear. In the **Device Manager** the listings for the port (under **Ports (COM & LPT)**) will be gone.

This procedure will not affect other ports or the card itself. To uninstall the card and all its ports use the preceding procedure.

Removing INF and PNF Driver Files

1. Open Windows Explorer as follows: From the **Windows Desktop**, click **Programs** → **Accessories** → **Windows Explorer**
2. Under the Windows directory expand the inf sub-directory and find the oemX.inf and oemX.PNF files (where X represents the number of the file).

The operating system names these files during the installation process. To locate the correct INF files, search for files in **C:\Windows\Inf** and its subdirectories for a file named *.INF that contains the text “**Disk #6404**”. There will be two files, unless the installation failed, then there might only be one file. Then, the customer can double-check that it is in fact a B&B Electronics file.

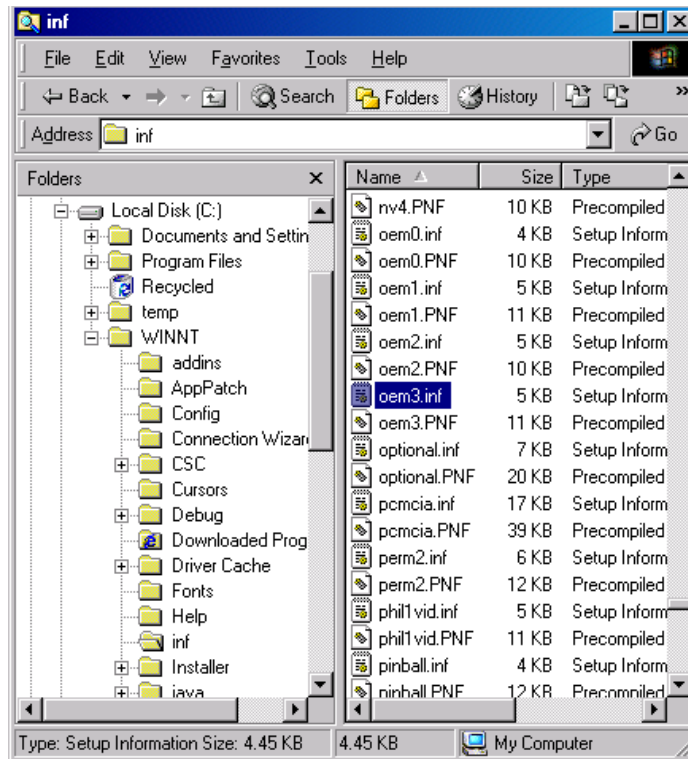

Figure 38. Finding the INF files in Windows Explorer

To find these files you may need to set your Views (under My Computer) to show all files and folders if the INF directory and .inf files are not visible.

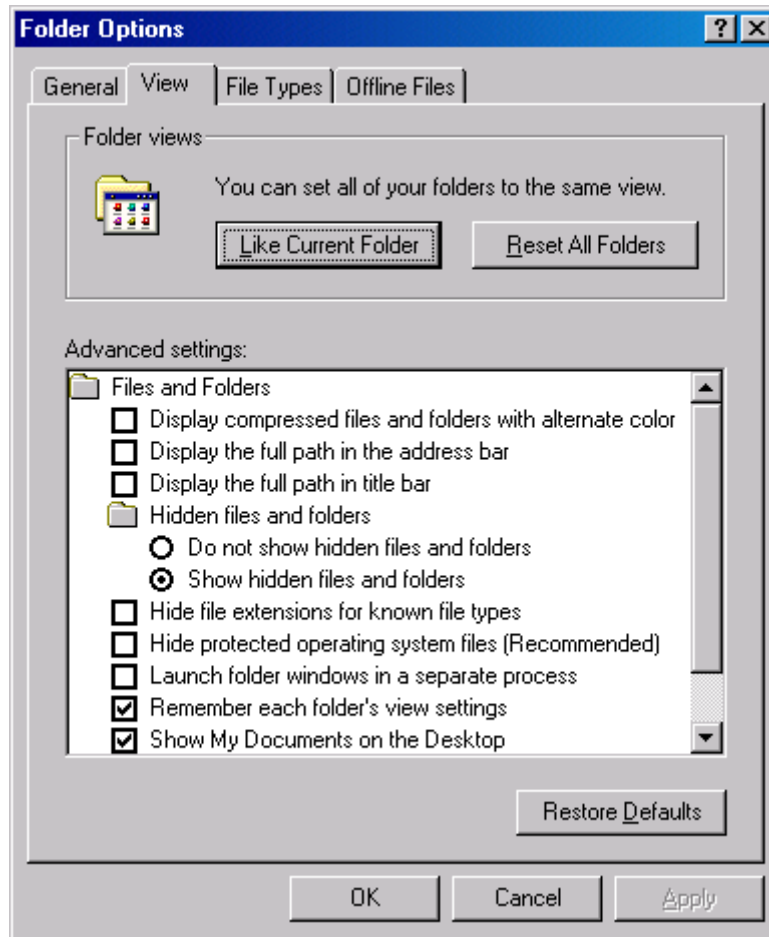

Figure 39. Setting the Folder Options to Display Hidden Files

3. Delete the oemx.inf and oemx.pnf files found in Step 2..

CAUTION! Be careful to delete only the files associated with the PCI card you are trying to uninstall.

Removing Mlport Cards from Windows NT

Uninstalling the Mlport Card

1. The Driver must be uninstalled.

Uninstalling the Driver

1. Using **Windows NT Explorer** locate the **uninstall.exe** file in the B&B installation directory. (The default installation directory is **C:\Program Files\B&B Electronics\Mlport**)

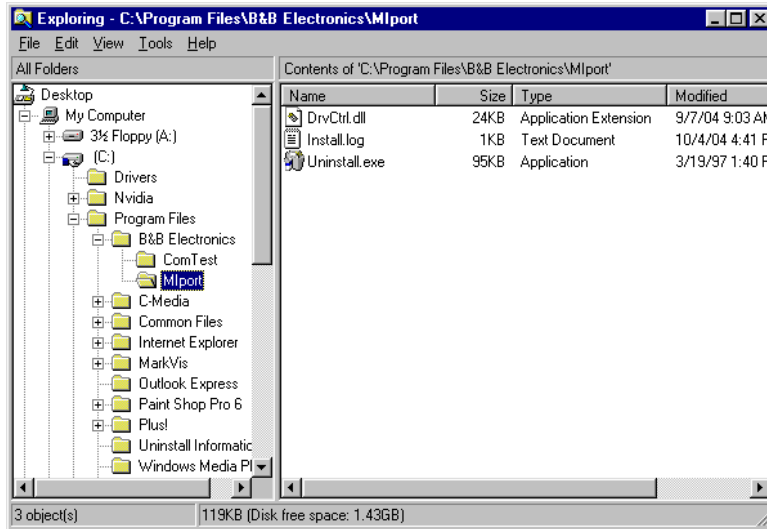

Figure 40. Uninstall.exe in the B&B Program Files

2. Double-click the Uninstall.exe file name. The **Select Uninstall Method** dialog will appear.
3. Select **Automatic** and click **Next**. The **Perform Uninstall** dialog will appear.
4. Click **Finish**.
5. Return to **Windows NT Explorer** and refresh the window (Click **View**, then click **Refresh**). The Mlport subdirectory under **C:\Program Files\B&B Electronics** should no longer be there.

Chapter 7: RS-232 Connections/Operation

RS-232 Mode

In RS-232 Mode MIport serial ports function as buffered standard PC serial ports and operate as DTEs (Data Terminal Equipment). RS-232 interfaces are commonly used for communications with modems, serial printers, and computer-controlled devices such as security equipment, bar code scanners and point-of-sale devices.

RS-232 Signal Designations and DB-9 Pinout

RS-232 Mode supports eight single-ended signal lines and signal ground. The DB-9 male connector is configured as a standard RS-232 (DTE) serial port. The table below shows the signal names and pin numbers.

RS-232 Signal Name	RS-232 Signal Description	Direction (DTE)	DB-9M Pin
DCD	Data Carrier Detect	Input	1
RD	Receive Data	Input	2
TD	Transmit Data	Output	3
DTR	Data Terminal Ready	Output	4
GND	Signal Ground	-----	5
DSR	Data Set Ready	Input	6
RTS	Request to Send	Output	7
CTS	Clear to Send	Input	8
RI	Ring Indicator	Input	9

Figure 41. RS-232 Signal Designations and DB-9 Pinout

Note: Refer to Appendix B for additional cable configurations and pinouts

RS-232 Signal Designations

The primary RS-232 signals are **TD** (transmit) and **RD** (receive). Together with GND (ground), they often are referred to as a “3-wire” interface.

The **RTS** (Request to Send) and **CTS** (Clear to Send) signals are handshaking lines used to indicate to the other device that data can be sent or received. These lines may be enabled or disabled on a byte-by-byte basis and are used to prevent buffer overrun or the loss of data.

Two secondary handshaking signals are **DTR** (Data Terminal Ready) and **DSR** (Data Set Ready). They are usually enabled when the device is powered up and the port is open. They may be used for flow control by some devices instead of RTS and CTS.

DCD (Data Carrier Detect) is used by a modem to indicate Carrier to the computer so data can be sent/received.

RI (Ring Indicator) is output by a modem to indicate that the phone or FAX line has an incoming call, so it can be handled.

DTE and DCE

There are two types of RS-232 ports:

- **DTE** (Data Terminal Equipment) which is typically a computer
- **DCE** (Data Communications Equipment) which is typically a modem.

Data Terminal Equipment (DTE)

When a DTE is connected to a DCE they are linked directly together using a modem cable wired pin to pin so that the inputs match the outputs of the other.

Data Communications Equipment (DCE)

When two pieces of equipment of the same type are interconnected (a DTE connected to a DTE, or a DCE to a DCE), a crossover (often called a null modem) cable is needed to route the outputs of one to the inputs of the other. This type of cable is needed to interconnect two computers with RS-232.

Note: Refer to Appendix B for straight-through and null modem cable diagrams and pinouts.

RS-232 Signal Levels

RS-232 signal lines are referenced to ground, and each signal can alternate above and below ground. The RS-232 standard specifies output voltages must be no less than +5 volts and no greater than +25 volts to represent a Space on a transmit line (or an asserted handshake line). Output voltages must be between -5 volts and -25 volts to represent a Mark on a transmit line (or an de-asserted handshake line).

The standard specifies that RS-232 inputs accept voltage levels between -3 volts and -25 volts for a Mark (asserted handshake) and between +3 volts to +25 volts for a Space (de-asserted handshake). Typically RS-232 voltages will be between +3V to +11V and -3V to -11V.

Handshaking

To control the flow of data between two devices, some software uses hardware handshaking. RS-232 devices which require hardware handshaking require connection of RTS/CTS and/or DTR/DSR lines in order to operate properly.

Programs for RS-232 may chose to use only the RS-232 TD and RD data lines and ignore hardware handshaking inputs (set up as None in the port configuration). In some cases the software may require connections to verify that a cable is connected and the devices are ready for access (typically DTR/DSR is used).

Some devices may use software handshaking in which data characters (e.g. Xon/Xoff) are sent to start and stop the incoming or outgoing data. These unprintable characters have the decimal value (17) and (19), and can often be generated in a terminal program with CTL+Q or CTL+S.

RTS Control In RS-232 Mode

In RS-232 mode, MPort cards support software and hardware handshaking. Handshake lines can be controlled from the communications software used with your application. When operating a MPort card port in RS-232 mode, set the **RTS Control** driver setting to **Normal**. This ensures that the RTS line will be free to be controlled by your software. If your communications software uses software handshaking, hardware handshake lines will not be required.

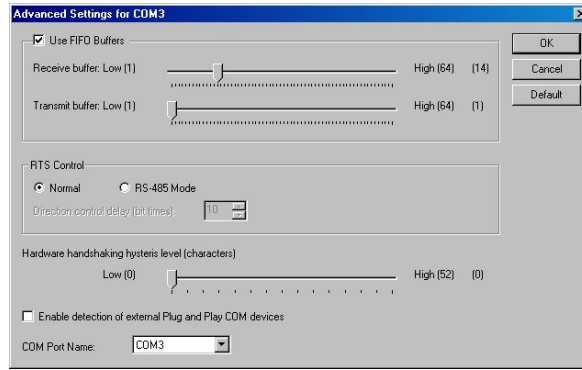

Figure 42. RTS Control – Select Normal for RS-232 Operation

Chapter 8: RS-422/485 Connections/Operation

RS-422/485 Mode

In RS-422/RS-485 mode MIport serial ports provide two sets of differential signal pairs and signal ground for each port. The RS-422 and RS-485 standards use balanced differential drivers and receivers for each signal. This facilitates greater communication distances than unbalanced systems such as RS-232.

RS-422 operation is suitable for interconnecting a computer and one device for full duplex (point-to-point) bi-directional communication, or a computer and several devices for unidirectional (point-to-multipoint) communication. RS-422 interfaces are commonly used for video editing/control, camera control, electronic signage, television studio/satellite dish control, performance lighting and audio equipment control.

RS-485 operates with the same signals and signal levels as RS-422 but differs in that it allows multiple devices to share the same communication link using half duplex (2-wire) or full duplex (4-wire) connections. RS-485 interfaces are commonly used in manufacturing and industrial/commercial control applications such as programmable logic controllers, telemetry, and process control.

RS-422/485 Signal Designations and DB-9 Pinout

Name	Description	Direction	DB-9 M Pin
RD(A) –	Receive Data A	Input	1
TD(B) +	Transmit Data B	Output	2
TD(A) –	Transmit Data A	Output	3
GND	Signal Ground	-----	5
RD(B) +	Receive Data B	Input	9

Figure 43. RS-422/485 Signal Designations and DB-9 Pinout

Note: Refer to Appendix B for additional cable configurations and pinouts

RS-422/485 Signal Designations

Typically RS-422 and RS-485 interfaces use five lines including two signal pairs and ground. One signal pair is the transmit pair, labeled **TD(A)-** and **TD(B)+**. The other signal pair is the receive pair, labeled **RD(A)-** and **RD(B)+**. Signal ground is labeled **GND**.

RS-422/485 Differential Signals

In RS-422 and RS-485 interfaces signals are sent on differential pairs. In the idle, or Mark, state, the TD(A)- line will be 0V with respect to (wrt) ground and the TD(B)+ line will be about 4.4V wrt ground. Sensing differentially across the two lines, the voltage will be -4.4V (representing a Mark state). When the transmitter changes to the Space state TD(A)- goes to $+4.4\text{V}$ and TD(B)+ goes to 0V. In that state the differential voltage will be $+4.4\text{V}$.

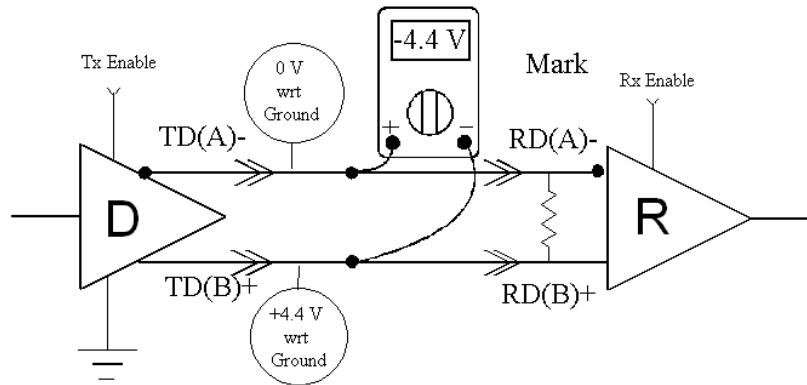

Figure 44. Differential transmitter/receiver

The receiver input is a differential circuit which senses the difference in voltage across the transmission line as described above. In addition, any common mode noise picked up equally on both wires of the twisted pair is cancelled. Receiver sensitivity is rated at 200mV. A separate signal ground/common connection provides a common mode reference for the transmitter and receiver (and is often used to ground a shield in the cable). These factors provide reliable communications at much greater distances than RS-232.

RS-422 Operation

In RS-422 mode, the transmitter is enabled (TX ENABLE) all the time, and the receiver is enabled (RX ENABLE) all the time. Typical point-to-point connections use a transmitter and receiver at each end with two wire pairs connecting them. The transmit lines of the device at one end of the link are connected to the matching receive lines of the device at the other end. The second device transmit lines are connected to the receive lines of the first.

Another common connection mode—point to multipoints—connects the transmit pair from the master device transmitter to the receive lines of many listening slave devices. In this scenario the communications is one-way. None of the listening devices have transmitters connected to reply to the master.

RS-422 Limitations

The limitation of RS-422 operation is that only one transmitter can be connected to a wire pair because the transmitter is active all the time. Even when the transmitter is not sending data it will assume the idle, or Mark, state in which TD(A)- is at 0V with respect to ground and TD(B) line is at about 4.4V with respect to ground. If another transmitter output is connected to the same wire pair, and attempts to begin sending data by setting the line pair to Space state, the first transmitter will hold the opposite state and neither can communicate. To overcome this limitation, RS-485 mode was developed, in which transmitters connected to the line are put into a high-impedance (tri-state) state when not transmitting.

RS-485 Operation

RS-485 solves some of the limitations of RS-422, allowing multidrop communications using 2-wire and 4-wire connections from multiple transmitters and receivers.

To accomplish multidrop operation the transmit driver must be enabled only during transmit (by asserting the enable input (TX SD) of the transmitter) and tri-stated to a high impedance after the data has been sent. In the 2-wire (half duplex) mode, the receiver is enabled when not transmitting, and disabled (RX \overline{SD}) during transmit (called ‘echo off’ because it avoids having the device receive its own transmissions).

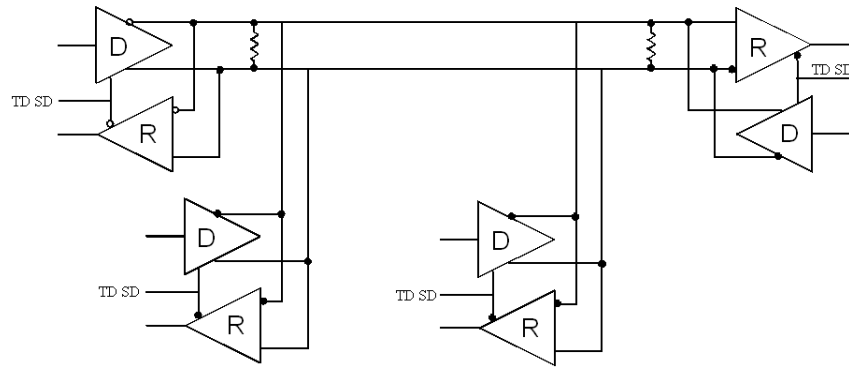

Figure 45. An RS-485 Two-Wire Multidrop Connection

Send Data Control

MIport cards provide Send Data Control (SDC) for the RS-485 driver and receiver. This is hardware controlled based on the contents of the UART output buffer. When data is present, the driver is enabled; when the output buffer becomes empty, it is disabled. This automatically handles whatever baud rate is used.

The RS-485 transmitter and receiver have separate settings for 2-wire modes (TX SD, RX SD) or 4-wire (TX SD, RX ENABLE).

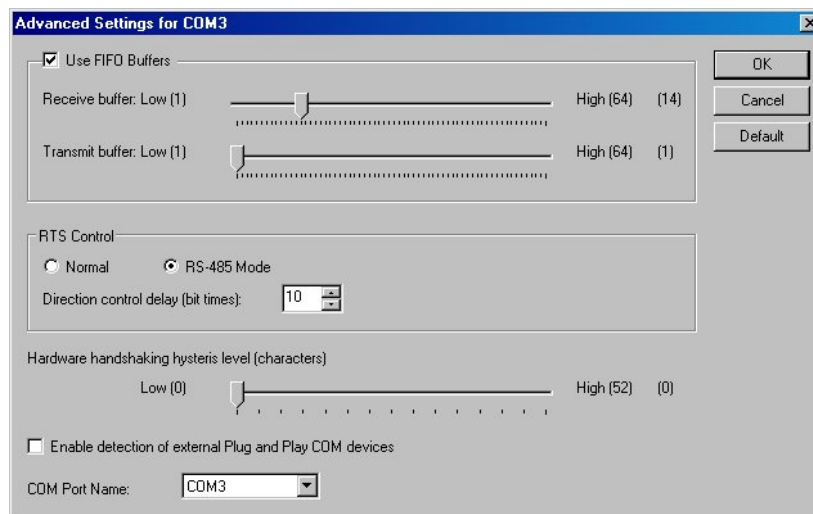

Figure 46. Setting RTS Control for RS-485

The RS-485 mode is set by configuring the DIP switch setting on the MIport card and by selecting **RS-485 Mode** under **RTS Control** in the Advanced COM port settings dialog box.

Note: For more information on COM port settings refer to Chapter 2 and Chapter 5

RS-485 Termination Resistors

In some applications termination resistors must be connected across the communications line to ensure reliable communications. Termination resistors absorb signal reflections that can occur when a data signal reaches the end of a transmission line and encounters an impedance higher than that of the transmission line itself. Typically termination resistors are not required for communications links that operate at less than 19.2 kbps. At higher bit rates a termination resistor of 120 ohms may be required. Termination resistors should be connected across the communications line at the extreme opposite ends of the network.

Through hole pads are provided on MIport cards to install termination resistors. When adding termination resistors the value of biasing resistors must be appropriately sized as well.

RS-485 Network Biasing

Unlike RS-422, where the transmitter holds the TD(B)+ line high and the TD(A)- line low (in the idle, or Mark state) when not transmitting data, in a RS-485 network, the transmitter tri-states to a high impedance state when not sending data.

It is important to maintain the Mark state for all RS-485 receivers when no data is being sent. Maintaining the line in the Mark state minimizes noise (that would otherwise be picked up by a high impedance line). It also provides the starting point so that when a transmitter begins to send data the leading edge of the start bit can transition from the Mark to Space state.

To maintain the Mark state biasing is required. Biasing is the technique of placing pull up (to positive voltage) and pull down (to ground) resistors on the line so that all RD(A)- receiver inputs remain at least 200 mV more negative than RD(B)+ inputs (Mark state). This ensures the inputs will remain above the receiver threshold of 200mV for all devices on that section of the network. If the biasing is not maintained, the first data bit of a signal may not be detected, and one or more devices may not respond to commands, or may operate intermittently.

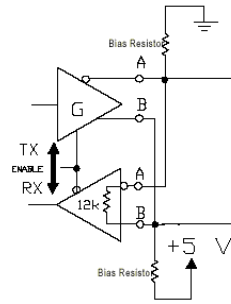

Figure 47. RS-485 Biasing Resistors

MIport RS-485 receivers come pre-biased from the factory with a 4.7 k Ω pull-up resistor on the RD(B)+ line and a 4.7 k Ω pull-down resistor on the RD(A)- line. These values are usually adequate for networks that do not implement termination resistors and have 31 or fewer nodes. When termination is used, biasing must be increased (resistors decreased), calculated according to the termination value and number of nodes.

Through hole pads are provided on MIport cards for adding termination resistors and bias resistors. The photograph below shows the layout of through hole pads for installing termination and bias resistors. On all MIport cards the top set of holes is for the termination resistor. The middle and bottom sets of holes are for bias resistors. (Note the factory installed 4.7k resistors in the photograph.) Since bias resistors are always the same value (e.g R pullup = R pulldown = 4.7k) there is no need to identify which set of holes is for pull up and which is for pull down.

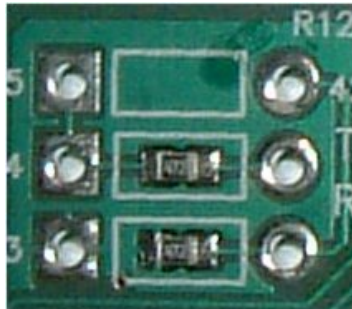

Figure 48. Termination and Bias Resistor Placement

Note: For more information on termination, biasing and how to calculate resistor values download the RS-422/485 Application Note from www.bb-elec.com

2-Wire RS-485 Connections

The following diagram shows how to wire the DB-9 connector that will plug into your MIport card for 2-wire RS-485 operation.

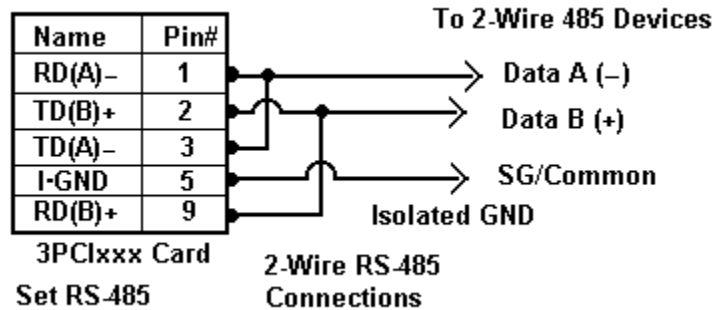

Figure 49. 2-Wire RS-485 Connections

2-Wire RS-485 Mode:

Your cables must bridge pins #1 & #3 and pins #2 & #9 in order to receive and transmit. Connect from Pin #2 to Data B(+) of your devices and from pin #3 to Data A(-) of your devices. Make sure your DIP switches are set, and that the driver Setting for RTS Control is **RS-485 Mode** in the Device Manager, Port Settings, Advanced.

Note that the EIA RS-422 Specification labels data lines with an "A" and "B" designator. Some RS-422 or RS-485 equipment uses a "-" and "+" designator. In most cases, the "A" line is the equivalent of the "-" line and the "B" line is the equivalent of the "+" line. Some device manufacturers may not follow the standard designation for RS-422 or RS-485, using the A connection for "+" and the B for "-". In such cases, reversing the line pair permits operation.

4-Wire RS-422 and RS-485 Connections

RS-422 Point to Point Connection

For RS-422 point to point communications connect the MIport card and to one RS-422 device only.

1. Connect the TD(B) pin #2 on the computer to RD(B) on the device.
2. Connect the TD(A) pin #3 on the computer to RD(A) on the device.

3. Connect the RD(B) pin #9 on the computer to TD(B) on the device.
4. Connect the RD(A) pin #1 on the computer to TD(A) on the device.
5. Connect the Signal Ground pin #5 to Signal Ground on the device.

RS-422 Point to Multipoints Connection

In a multi-slave RS-422 connection, TD(B) and TD(A) connect to RD(B) and RD(A) on all the slaves. If the slaves have Transmit connections, only one device can be connected back to the master.

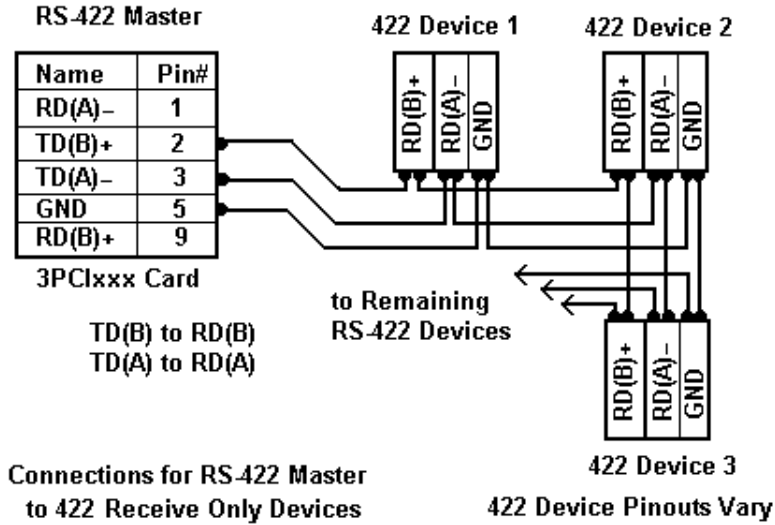

Figure 50. RS-422 Master to RS-422 Receive Only Devices

4-Wire RS-485 Connection

In a 4-wire RS-485 system, each receive line connects to the same receive terminal on all slaves, and each transmit line connects to the same transmit terminal on all slaves. The master to the first slave is connected as above.

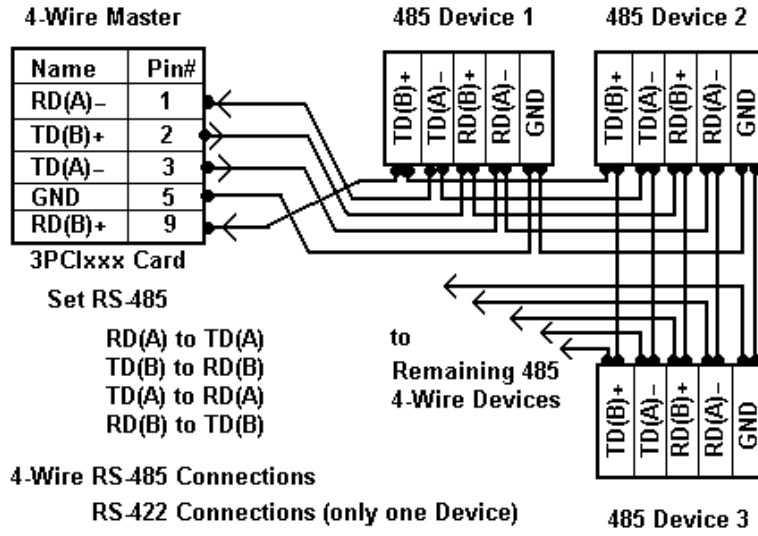

Figure 51. 4-Wire RS-422 or RS-485 Connections

Chapter 9: Troubleshooting Mlport Cards

Your Mlport card should be fully functional when you receive it from the factory. Operational problems encountered on first use will typically be the result of incorrect connections or operation. The following procedure will assist you in locating the source of you problems.

Starting Up

If you have any trouble starting your system after installing the card, the card may not be properly seated in the slot. Power down the computer, remove and re-insert it, or try a different slot. Ensure your system is set for PnP OS. (Windows NT and Linux should be set to non-PnP.)

Checking Connections

RS-232/422/485 Operation

1. Ensure that you have set up your card for the correct mode of operation (RS-232, RS-422, RS-485 2-wire or 4-wire) using the DIP switches on the card and Advanced Port Settings.

Note: For more information on DIP switches refer to Chapter 2. For more information on Driver Settings refer to Chapter 5.

2. Ensure your communications parameters (baud rate, parity, stop bits) are set correctly at both ends of your link.

RS-232 Operation

1. Mlport cards are DTE devices. If you are connected to a DCE device use a straight through cable. If you are connected to another DTE device, use a crossover, or null cable.
2. If hardware handshaking is required, ensure you have the right cables and that both ends of your link are configured the same for handshaking.

RS-422/485 Operation

1. Check your pinouts. In RS-422 or RS-485 mode the "A" lines should match your "A" or "-" lines. "B" lines should match your "B" or "+" lines.

Note: RS-422/485 pinouts are non-standard.

2. Make sure you have RTS Control set to the correct mode: Normal for RS-232, RS-485 Mode for RS-485. RS-422 mode works in either setting if the mode jumpers are set correctly.

Checking the Mlport Card

Using ComTest and a loopback connection, you can check the operation of your Mlport card separate from the rest of your communications system.

Note: Refer to Appendix C for information on how to install and use ComTest

1. A loopback connection for RS-232 connects the Transmit output to the Receive input (pins #2 & #3 on the DB-9 connector). Use connections below to check all.

RS-232 Loopback Connections

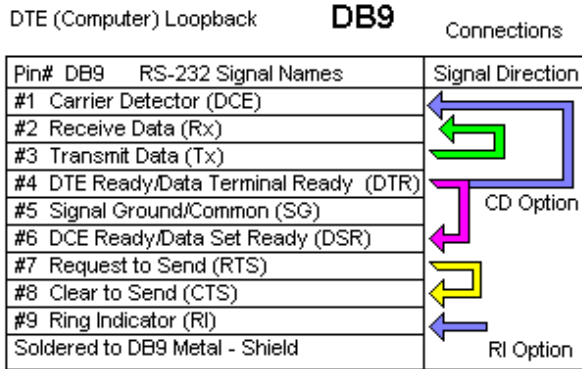

Note: CD & RI are inputs from Modem device - use DTR Connection

Figure 52. RS-232 Loopback w/Handshaking Connections

2. For RS-422 or 4-wire RS-485, connect the TD(A) to RD(A) and the TD(B) to RD(B). Then use the ComTest program to send characters, and observe the characters being received.

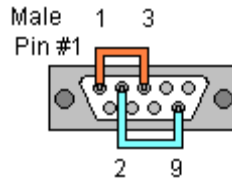

Figure 53. RS-232 Loopback Connector

3. To check 2-wire RS-485 RS-422 or 4-wire RS-485 Loopback Connections, you must either enable the receiver by moving the receive jumper to RX ENABLE mode, or use one port to transmit to another 2-wire RS-485 port or converter by cross connecting and loading ComTest twice, one copy for each port.

Characters typed in one copy of ComTest will appear in the receive window of the other. Note that software must ignore the RS-232 handshaking lines in RS-422/RS485 mode, the input lines (CTS, DSR, DCD, RI) are not pulled high.

4. Some manufacturers label their data connections for A and B reverse of the standard for RS-422 or RS-485, so that the A line is (+) and B line is inverted (-) following the IC standard. In such a case, just swap the wires and try it. No damage occurs in the RS-485 mode, just no devices will respond. The EIA standard for signal labels defines the B line as positive relative to A during the “MARK” state.
5. Try another software package for troubleshooting. Some applications try to bypass the Windows drivers and access the hardware directly.
6. Check the B&B website for available FAQs or troubleshooting hints.
7. Contact B&B Electronics Technical Support for troubleshooting assistance.

Support

USA Office

Technicians are available at (815) 433-5100 to answer your questions from 8 AM - 5 PM weekdays (Central Time).

Email: support@bb-elec.com

European Office

Technicians are available at +353 91 792444 to answer your questions from 8:30 AM – 5 PM weekdays (GMT).

Email: support@bb-europe.com

Appendix A: DIP Switch/Mode Settings

Setting the DIP Switches on RS-232/422/485 Ports

Set the DIP switches to configure the desired operating mode as follows:

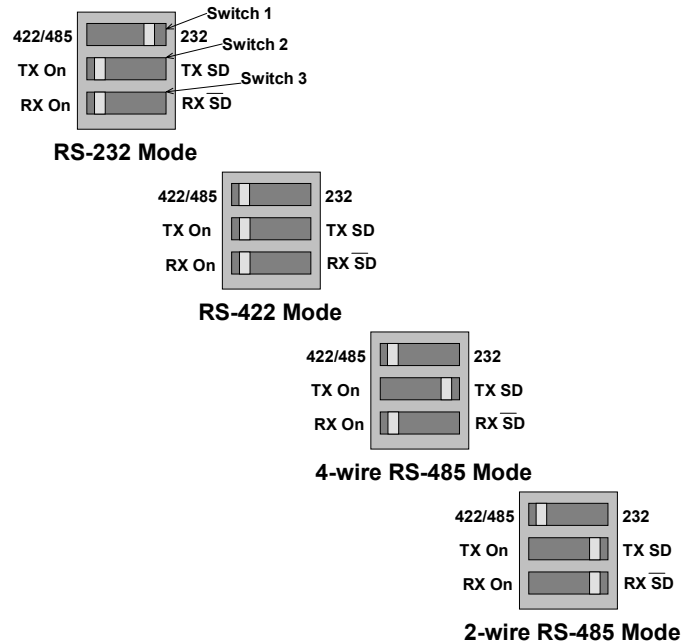

Figure 54. RS-232/422/485 DIP Switch Settings.

DIP Switch 1 (RS-232/422/485 ports)

The top DIP switch (1) configures the port for RS-232 or RS-422/485 operation. This switch is the only one that is required to be set for RS-232 operation. The positions of switches 2 and 3 do not matter when switch 1 is set for RS-232 operation.

DIP Switch 2 (RS-232/422/485 ports)

The middle DIP switch (2) configures the port for RS-485 or RS-422 operation. For RS-422 operation (which uses two wire pairs and sends point-to-point or point-to-multipoints) the transmitter can be enabled all the time. Placing the middle DIP switch in the TX ON position accomplishes this.

For RS-485 operation the middle DIP switch is placed in the TX SD position. In this position the transmitter is only enabled when data is being sent. The transmitter is tri-stated when not sending data, allowing other transmitters on the communications line to transmit without interference.

DIP Switch 3 (RS-232/422/485 ports)

The bottom DIP switch (3) configures the port for half-duplex (two-wire) RS-485 operation or full-duplex (four wire) RS-422/RS-485 operation. Placing the bottom DIP switch in the RX ON position configures the port for four wire operation. In this mode the receiver is continuously enabled, allowing it to receive all data on the communications line. Since the transmitter sends data on the other wire pair the port does not receive its own transmissions.

Placing the bottom DIP switch in the RX \overline{SD} position configures the port for two wire operation. In this mode the transmitter and receiver are connected to the same wire pair. The receiver is disabled when its transmitter is sending, preventing the port from receiving its own data.

Setting the DIP Switches on RS-422/485 Only Ports

The 3PCIU4 MIport card provides a combination of RS-232/422/485 and RS-422/485 only ports. Ports that do not include RS-232 operation use double DIP switches rather than triple DIP switches. These DIP switches operate the same as the two bottom DIP switches in the RS232/422/485 ports

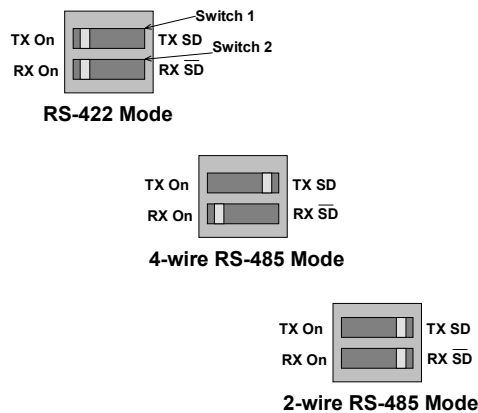

Figure 55. RS-422/485 only DIP Switch Settings

DIP Switch 1 (RS-422/485 only)

The top DIP switch (1) configures the port for RS-485 or RS-422 operation. For RS-422 operation (which uses two wire pairs and sends point-to-point or point-to-multipoints) the transmitter can be enabled all the time. Placing the middle DIP switch in the TX ON position accomplishes this.

For RS-485 operation the middle DIP switch is placed in the TX SD position. In this position the transmitter is only enabled when data is being sent. The transmitter is tri-stated when not sending data, allowing other transmitters on the communications line to transmit without interference.

DIP Switch 2 (RS-422/485 only)

The bottom DIP switch (2) configures the port for half-duplex (two-wire) RS-485 operation or full-duplex (four wire) RS-422/RS-485 operation. Placing the bottom DIP switch in the RX ON position configures the port for four wire operation. In this mode the port's receiver is continuously enabled, allowing it to receive all data on the communications line. Since the port's transmitter sends data on the other wire pair the port does not receive its own transmissions.

Placing the bottom DIP switch in the RX \overline{SD} position configures the port for two wire operation. In this mode the port's transmitter and receiver are connected to the same wire pair. The receiver is disabled when its transmitter is sending, preventing the port from receiving its own data.

Appendix B: CONNECTOR PINOUTS

RS-232 Pinouts

Name	Description	Direction (DTE)	DB-9M Pin
DCD	Data Carrier Detect	Input	1
RD	Receive Data	Input	2
TD	Transmit Data	Output	3
DTR	Data Terminal Ready	Output	4
GND	Signal Ground	-----	5
DSR	Data Set Ready	Input	6
RTS	Request to Send	Output	7
CTS	Clear to Send	Input	8
RI	Ring Indicator	Input	9

Figure 56. RS-232 Signal Designations and DB-9 Pinout

Signal Name	DB-9 Pin (DTE)	DB-25 Pin (DTE)
DCD	1	8
RD	2	3
TD	3	2
DTR	4	20
GND	5	7
DSR	6	6
RTS	7	4
CTS	8	5
RI	9	22
Chassis GND	Shield (DB-9 Shell)	1

Figure 57. RS-232 DB-9 to DB-25 Conversion Cable Pinout

RS-422/485 Pinouts

Name	Description	Direction	DB-9M Pin
RD(A) -	Receive Data A	Input	1
TD(B) +	Transmit Data B	Output	2
TD(A) -	Transmit Data A	Output	3
GND	Signal Ground	-----	5
RD(B) +	Receive Data B	Input	9

Figure 58. RS-422/485 Signal Designations and DB-9 Pinout

With 2-wire RS-485 mode operation, your connection cable must jumper TD(A) to RD(A) and TD(B) to RD(B). Connect from TD(A) and TD(B) to the Data A(-) and Data B(+) wires of your RS-485 network.

Note: Refer to Chapter 2 for example connections.

Note that the EIA RS-422 Specification labels data lines with an "A" and "B" designator. Some RS-422 equipment uses a "-" and "+" designator. In almost all cases, the "A" line is the equivalent of the "-" line and the "B" line is the equivalent of the "+" line.

Note: For more information on RS-422 communications refer to the B&B Electronics RS-422/485 Application Note at www.bb-elec.com

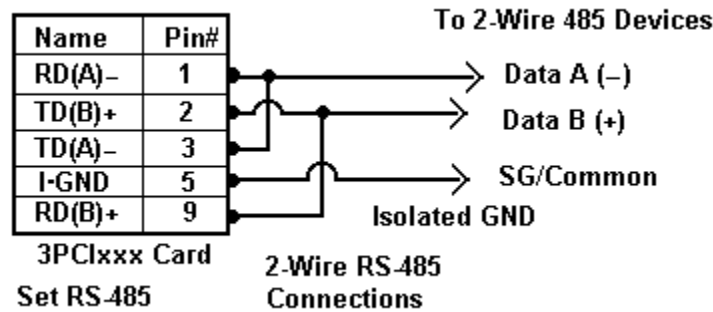

Figure 59. 2-Wire RS-485 Wiring Diagram

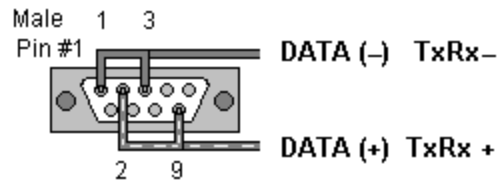

Figure 60. 2-Wire RS-485 Wiring

Appendix C: Troubleshooting With ComTest

ComTest is a simple 32-bit Windows (Windows 98, 2000, 2003 Server, ME, XP, NT 4.0 and Vista) COM port test program included on the MIport CD. (It can also be downloaded from the B&B Electronics website at: www.bb-elec.com. The program allows multiple ports at any address and IRQ, to be opened at any given time.

ComTest Features

- A Windows Terminal Program for Simple Checks of Serial Ports. Works with USB Serial Converters & ISA or PCI Serial Cards
- Serial Port Access under Windows 98/2000/2003 Server/XP/Vista – COM1-COM8 or above.
- Dual Windows show typed transmit characters in a separate window from received characters.
- Transmit & Receive Activity Indicators
- Unprintable Characters Shown in Hex – 2 Digits Within Left & Right Angle Brackets.
- Visual Indication of Handshaking Lines – DTR DSR DCD and RTS CTS. (Red = Hi)
- Option for Setting DTR or RTS lines high or low.
- Option for Repeat Mode – last character or Function Character Sequence is repeated until set off.
- Configuration Settings:
 - Baud Rates 150, 300, 600, 1200, 2400, 9600, 19.2, 28.4, 57.6, 115.2K (9600 default and recommended)
 - Parity: None, Odd, Even, Mark, Space (None default)
 - Data Bits: 5, 6, 7, 8 (8 default)
 - Stop Bits: 1, 1.5, 2 (1 default)

Installing ComTest

1. From Windows Explorer, under Windows, Programs, COMTest, find the setup.exe file on the MIport CD.

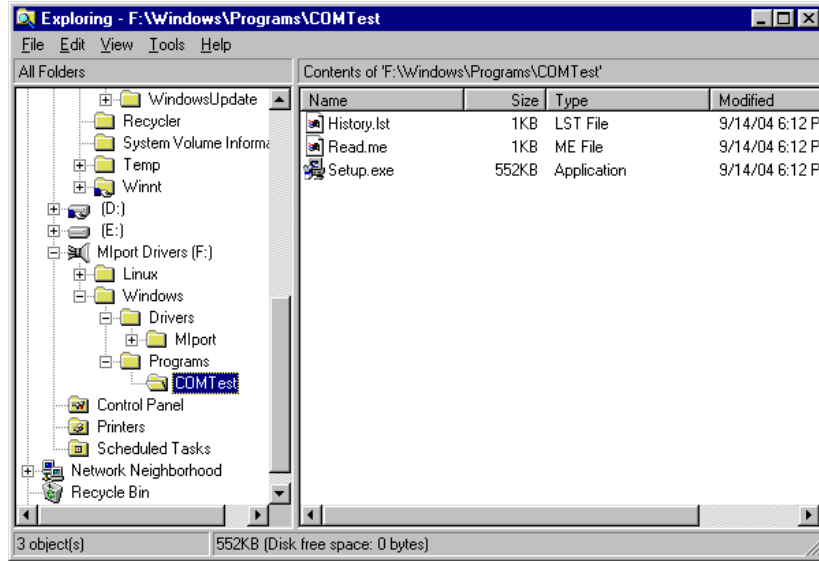

Figure 61. Loading ComTest

2. Run Setup.exe to install ComTest on your program menu under B&B Electronics.

Loopback Testing with ComTest

To familiarize yourself with the operation of ComTest connect a loopback plug to a COM port on your PC and perform the following procedure:

1. Make any required loopback connections on the port to be tested.

RS-232 Loopback Connections

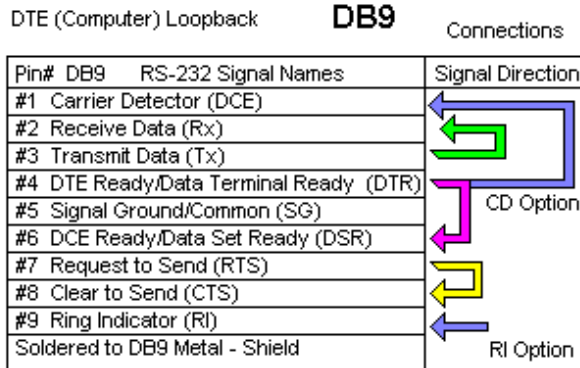

Note: CD & RI are inputs from Modem device - use DTR Connection

Figure 62. RS-232 Loopback w/Handshaking Connections

- From the **Windows Desktop** click **Start** → **Programs** → **B&B Electronics** → **ComTest** → **ComTest**.

ComTest will start and then open the **Select Port** dialog box.

- Select the COM port you want to access or test. (The drop down box shows available ports that are not currently in use).
- Click **OK**. The **Configure Port** dialog will appear.
- Select the desired baud rate, parity, data bits, stop bits. (Defaults are common settings).
- Type characters. They will appear in the upper window.

If you are performing a loopback test, you should see the characters appear in the lower window as they are received.

- On the **Option** menu, click **DTR** to assert or de-assert the DTR hardware handshake line. The DTR indicator at the bottom of the window will be red when asserted.

If DTR is looped back to DSR and DCD their indicators should also be red.

- On the **Option** menu, click **RTS** to assert or de-assert the RTS hardware handshake line. The RTS indicator at the bottom of the window will be red when asserted.

If RTS is looped back to CTS, the CTS indicator should be red.

9. When testing is completed, close the program.

Note: For more information on using ComTest to troubleshoot Mport cards and software see Chapter 7.

Appendix D: Declaration of Conformity Statement

DECLARATION OF CONFORMITY

Manufacturer's Name: B&B Electronics Manufacturing Company
Manufacturer's Address: P.O. Box 1040
707 Dayton Road
Ottawa, IL 61350 USA
Model Numbers: 3PCIoUx Universal PCI Cards
Description: Optically Isolated Serial PCI Card
Type: Light industrial equipment
Application of Council Directive: 89/336/EEC
Standards: EN 55022
EN 61000-6-1
EN 61000 (-4-2, -4-3, -4-4, -4-5, -4-6, -4-8, -4-11)



Michael J. Fahrion, Director of Engineering





International Headquarters

B&B Electronics Mfg. Co. Inc.
707 Dayton Road
Ottawa, IL 61350 USA

Phone (815) 433-5100 -- **General Fax** (815) 433-5105

Website: www.bb-elec.com

Sales e-mail: orders@bb-elec.com -- **Fax** (815) 433-5109

Technical Support e-mail: support@bb.elec.com -- **Fax** (815) 433-5104

European Headquarters

B&B Electronics
Westlink Commercial Park
Oranmore, Co. Galway, Ireland

Phone +353 91-792444 -- **Fax** +353 91-792445

Website: www.bb-europe.com

Sales e-mail: sales@bb-europe.com

Technical Support e-mail: support@bb-europe.com